

INDEX

PART- A
3 PHASE ELECTRIC LOCO OPERATING INSTRUCTIONS

	PAGE
1. Technical data	4
2. Abbreviations	6
3. General features of 3 phase electric loco	8
4. Advantages of 3-phase electric locomotives	10
5. Mechanical features of 3 phase electric loco	11
6. System description	13
6.1 Potential transformer	13
6.2 Main transformer	13
6.3 Traction power circuit	15
6.3 .1 Traction converter	16
6.3.2 Line converter	18
6.3.3 DC link	18
6.3.4 Drive converter	18
6.3.5 Technical data of traction converter	18
6.4 Traction motor:	18
6.4.1 Technical data of traction motor	19
6.5 Auxiliary converter:	20
6.5.1 General	20
6.5.2 3 Phase, 415 volt auxiliaries	22
6.5.3 Load sharing	22
6.5.4 Main compressor 1 & 2	23
6.5.5 Single – ph.415 v/110 v aux. Circuit	24
6.6 Cooling concept	25
6.7 Harmonic filter	26
6.8 Battery	26
6.9. Brake system:	27
6.9.1 Automatic train brake- (A-9)	27
6.9.2 Direct brake -(SA-9)	30
6.9.3 Anti spin brakes	33
6.9.4 Brakes through blending valve	34
6.9.5 Synchronous Loco Brakes	34
6.9.6 Parking brake	34
6.9.7 Failure of brake electronics	36
6.9.8 Regenerating braking	36

6.9.9	An emergency braking operation	37
6.10	Miscellaneous:	37
6.10.1	Pantograph	37
6.10.2	MCPA	38
6.10.3	Main reservoir	38
6.10.4	Memotel	38
6.10.5	Sanding	39
6.10.6	Control Electronics	39
6.10.7	Active functions with Deactivated driver's cab	39
6.10.8	Resetting of MCB	40
6.10.9	Flasher light	40
6.11	KNORR'S Computer Control Brake System	41
7.	Do's and Don'ts	48
8	Protective Measures:	50
8.1	Catenary voltage out of range	50
8.2	Temperature protection	50
8.3	Primary over current protection	50
8.4	Train Parting	50
8.5	Fire Alarm	51
8.6	Alarm chain Pulling	52
9	Preparation:	53
9.1	Loco preparation and inspection	64
10	On line movement (Different operations)	66
10.1	How to energise the loco	66
10.2	Operation of BL key	67
10.3	Driving mode	67
10.4	Self hold mode	68
10.5	Switching off - control electronics	68
10.6	Cooling mode	68
10.7	Operation of Reverser	69
10.8	Driving	69
10.9	Braking	69
10.10	Operation of throttle	70
10.11	Failure mode operation	70
10.12	Loco brake testing	71
10.13	How to change the cab	71
10.14	Banking mode	72
10.15	Constant speed controller	72
10.16	Emergency stop push button	73
10.17	Vigilance control device:	73
10.18	Passing neutral section	75

11.	Fault Diagnostics	76
11.1	Display screen	77
11.2	Screen structure	77
11.3	Faults with priority.1	78
11.4	Faults with priority-2	78
11.5	Isolation of sub system	78
11.6	Acknowledgement of fault message	78
11.7	Indication and recognition of faults	79
11.8	Status code	80
11.9	Fault message code	80
11.10	Display of subsystem status	81
11.11	Browse of status messages on request	81
11.12	Diagnosis messages	81
11.13	Isolation message code	82
11.14	List of subsystems	84
11.15	List of isolation messages	84
11.16	List of information messages	85
12.	Multiple Unit	86
13.	Wheel Lifting Procedure	91
14.	Dead Loco Movement	96

**PART - B
TROUBLE SHOOTING DIRECTORY**

1	Trouble shooting directory	1 – 67
---	----------------------------	--------

**PART – C
DIFFERENT PHOTOGRAPHS OF LOCO PARTS**

1.	Different photographs of loco parts	1-12
----	-------------------------------------	------

Chapter – 1**TECHNICAL DATA**

Technical Data	WAP5	WAP-7	WAG9
Type of Service	Passenger	Passenger	Freight
Axle Arrangement	Bo-Bo	Co-Co	Co-Co
Gear Ratio	1:3.65	1:3.6	1:5.133
Gauge	1676 mm	1676 mm	1676 mm
Length over Buffer	18162 mm	20562 mm	20562 mm
Overall Width	3142 mm	3100 mm	3152 mm
Maximum Height with Pantograph Locked	4255 mm	4255 mm	4255 mm
Wheel Diameter New	1092 mm	1092 mm	1092 mm
Worn	1016 mm	1016 mm	1016 mm
Total Weight	78 T	123 T	123 T
OHE Voltage Nominal	25 kV	25 KV	25 kV
Minimum	17.5 KV	17.5 KV	17.5 kV
Maximum	30 kV	30 KV	30 kV
OHE Frequency Nominal	50 Hz	50 Hz	50 Hz
Minimum	45 Hz	45 Hz	45 Hz
Maximum	55 Hz	55 Hz	55 Hz

HAND BOOK ON 3-PHASE ELECTRIC LOCO

Power Supply to Auxiliary Frequency	415 V \pm 10% 0 to 59 Hz	415 V \pm 10% 0 to 59 Hz	415 V \pm 10% 0 to 59 Hz
No. of Auxiliary Converter	Aux. Conv. 1,2,3	Aux. Conv. 1,2,3	Aux. Conv. 1,2,3
Battery Voltage	110 V	110 V	110 V
Power Supply to Traction Motors	2180 V	2180 V	2180 V
No. Of Power Converters	2	2	2
Type of Traction Motor	Three phase Induction Motors	Three phase Induction Motors	Three phase Induction Motor
No. of Traction Motors	4 6FXA7059	6 6FRA6068	6 6FRA6068
Power of Traction Motor	1563HP	1156 HP	1156 HP
Tractive Effort	258 KN	322.6 KN	458 KN
Braking	Regenerative, Pneumatic, Parking, Anti Spin	Regenerative Pneumatic, Parking, Anti Spin	Regenerative, Pneumatic, Parking, Anti Spin
Braking Effort	160 KN	182 KN	260 KN
Parking Brakes:	Wheel No. 1,4,5 & 8	Wheel No. 2,6,7 & 11	Wheel No. 2,6,7 & 11
Horse Power	5440 HP	6120 HP	6120 HP
Maximum Speed	160 Kmph	130 Kmph	100 Kmph
Main Reservoir	3 nos	2 nos.	2 nos
Hotel Load	Available	Not available	Not available
Loco brakes	On Disc 5 kg/cm ²	On Wheel 3.5 kg/cm ²	On Wheel 3.5 kg/cm ²

Chapter- 2

ABBREVIATIONS

ALG	Drive Control Unit - Drive Inverter and Line converter Control
ASC	Driver Converter Control
ASR	Drive Converter
BL	Key switch
BLCP	Spring-loaded switch for Main compressors
BLDJ	Spring-loaded switch for Main circuit breaker
BLHO	Spring-loaded switch for Hotel load (not active on WAG-9)
BLPR	Switch Headlights
BPCS	Illuminated push-button, green for Constant speed control
BPFA	Illuminated push-button, yellow for Acknowledgement all fault Messages
BPFL	Illuminated push-button, yellow Emergency flashlight
BPPB	Illuminated push-button, red for parking brake
BPVG	Push-button, green for Vigilance
BPVR	Push-button, illuminated yellow for resetting vigilance
BUR	Auxiliary Converter
BZ-V-O-F	Buzzer for vigilance, over speed and fire
CEL	Central Electronics
CSC	Constant Speed Control
DDS	Diagnostic Data Set
FLG	Vehicle Control Unit
GTO	Gate Turn Off
HB	Cubicle Auxiliary Circuits
HBB	Processor
HRA	Switch Cab blower/heating
LSAF	Indication lamp, red for Train parting
LSCE	Indication lamp, amber for over temperature CEL
LSDJ	Indication lamp, red for Main Circuit Breaker
LSFI	indication lamp, red for Fault message, priority 1
LSHO	Indication lamp, yellow Hotel load (Not active on WAG-9)
LSP	Indication lamp, yellow for Wheel slipping
LSVW	Indication lamp, yellow for Vigilance Warning
MCB	Main Circuit Breaker
MCE	MICAS-S2 Control Electronics
MEMOTEL	Speed Recorder and Indicator
MR	Machine Room
MUB	Over voltage Protection Unit
NSR	Line Converter

Pan	Pantograph
PCLH	Socket Hand Lamp
PP	Pneumatic Panel
SB	Cubicle Control Circuits
SLG	Converter Control Unit
SR	Traction Converter
SS	Subsystem
STB	Low Voltage Cubicle Control
TE/BE	Tractive/braking effort
UBA	Voltmeter Battery Voltage
VCB	Vacuum Circuit Breaker - Main Circuit Breaker
ZBAN	Spring Loaded Switch- Banking operation
ZBV	Train Bus Administrator
ZLC	Switch for Driver's cab lighting
ZLDA	Switch for Assistant driver's desk illumination
ZLDD	Switch for Driver's desk illumination
ZLFR	Switch for Marker lights, red
ZLFW	Switch for Marker lights, white
ZLH	Switch for Socket hand lamp
ZLI	Switch for Instrument lighting
ZPRD	Switch for Headlights, intensity
ZPT	Spring-loaded switch for Pantograph
ZTEL	Switch for Max. Traction limitation
ZK	DC link

Chapter- 3**GENERAL FEATURES OF 3-PHASE AC LOCO****Advanced Technological Features: -**

In addition to the provision of latest 3-phase traction drive system; the 3 phase locomotives have certain improved technical features as compared to the conventional locomotives so being used on IR. Some major features are listed below.

3.1 Digital electronics based real time traction control**System: -**

To obtain precise control over tractive effort and speed in the normal mode and constant speed control mode of operation respectively.

3.2 Electrical weight transfer control system: -

To automatically reduce the tractive effort in the leading bogie and increase the same in the trailing bogie to take care of weight transfer effect.

3.3 Anti spin protection: -

When the ratio of requested and effected tractive effort goes below 0.5, anti spin protection initiated, which reduce the TE and apply loco brakes to stop spinning.

3.4 On-board fault diagnostics system: -

To eliminate/ elaborate trouble-shooting by engine crew and also to help maintenance staff to trace faults. The fault diagnostics system provides for automatic isolation of faulty equipment/ subsystems.

3.5 Simulation mode of operation: -

To facilitate a complete functional testing of the locomotive without raising pantograph.

3.6 An exclusive harmonic filter circuit: -

To reduce harmonics in the loco current

3.7 Static auxiliary converter: -

To supply auxiliary 3 phase motors. The auxiliary converter, depending on the traction load, operates at an optimum frequency to minimize power consumed by auxiliaries

3.8 Electronic speedometer: -

Paperless speed recording system. An over speed alarm system is built in.

3.9 Electronic energy meter: -

For information of energy generated and energy consumed

3.10 Fire detection and alarm system: -

For the machine room.

3.11 Low traction bar arrangement between bogie and body to reduce weight transfer :-

Unidirectional mounting of traction motors to further reduce weight transfer effect.

3.12 Ergonomically designed and spacious driving cabs: -

To provide comfort and relief to crew.

3.13 Use of inertial filters: -

Pressurized machine room to prevent entry of dust into sensitive equipment in the machine room.

3.14 Electronic brake system: -

For precise and fast control of braking effort, blending between electrical brake and pneumatic brake on the locomotive.

3.15 Triplet pneumatic brake panel :-

To minimize piping and provide single- place location of all pneumatic equipment.

3.16 Use of tread brake units: -

To reduce maintenance

3.17 Spring loaded parking brake system

Instead of handbrakes, spring loaded parking brakes are provided on this loco, these brakes can be operated from loco and remain applied without pressure by spring.

3.18 Over-charge feature in the brake system for faster release of brakes

For faster release of train brakes after recreation, BP is charged to 5.4 kg / cm² for short time with restricted dropping rate to 5.0 kg/cm².

3.19 Electronic controlled vigilance system

To keep the loco pilot alert Vigilance system is provided, As per this system, loco pilot has to do predetermined task once within 60 seconds, otherwise VCD will apply emergency braking.

3.20 Wheel Flange lubrication system: -

To reduce energy consumption and wheel wear.

3.21 Under-slung compressors: -

To eliminate oil fumes and oil spillage inside the machine room, which is potential causes for fire hazards.

Chapter- 4**ADVANTAGES OF 3-PHASE LOCOMOTIVES**

The merits of 3-phase locomotives over D.C.-motor locomotives are summarized below.

- 4.1 The size of traction motor for the same output power is much less in case of a 3-phase induction motor compared to DC motor. Therefore, with the permissible axle load and available space in a bogie, realization of a much higher-powered loco motive is possible.
- 4.2 Maintenance cost of a 3-phase locomotive is less due to absence of brush-gear/ commutator in the traction motors and switchgears in the power circuit.
- 4.3 Induction motors are very robust. Consequently reliability of a 3-phase locomotive is higher.
- 4.4 The rated power of a D.C.-motored locomotive reduces beyond the field weakening range. In case of 3-phase loco motives, full power is available up to the maximum speed.
- 4.5 Overload capabilities in 3-phase locomotives are more Liberal.
- 4.6 Regeneration of power is available in 3-phase locomotives. Regenerative braking effort is available from the full speed till dead stop. Consequently, the overall efficiency of operation is higher.
- 4.7 Due to superior drop characteristics of speed Vs. torque and the fact that the motor speed is limited by the synchronous speed, a much improved adhesion is available in 3-phase locomotive and thus higher tractive efforts can be realized within permissible axle load limits.
- 4.8 3-phase locomotive operates at near unity power factor throughout the speed range except at very low speeds.
- 4.9 Due to lesser weight of the traction motors, the un-sprung masses in 3-phase locomotive are low. This reduces track forces and consequently minimizes wear on rails and disturbance to track geometry.

Chapter- 5**Mechanical features of 3 phase AC loco.**

The three axles, three motor Co-Co bogie assemblies, is one of the major parts of the Locomotive. Two bogie assemblies support the entire weight of the 3 phase locomotive and provide a means for transmission of the tractive effort to the rails.

The bogies are designed to withstand the stresses and vibrations resulting from normal rolling stock applications. An important function of the bogie is to absorb and isolate shock caused by variations in the track bed. The suspension systems minimize the transmission of these shocks to the locomotive under frame.

The traction motors are suspended in the bogie frame and on the individual axles. The motors transmit their energy to the driving axles through a gearbox mounted on the driving axle. The force from the driving axles is transmitted to the contact point between the wheel tread and the rail. Traction force is, in turn, transmitted through the axle journal boxes and **guide rods** to the bogie frame. The **push-pull link rod**, connected between the bogie transom and loco under frame, transmits the tractive forces to the loco body.

As with the tractive effort, braking effort is transmitted to the bogie frame by the axle journal boxes and guide rods and from the bogie frame to the locomotive by the traction rods.

Isolation and absorption of shock loads and vibration is performed by the primary and secondary suspension. Movement between the loco body and bogie is smoothly controlled by the primary and secondary suspension. Although the springs permit free movement in any direction, **lateral buffers** and **dampers** limit the amount and rate of lateral movement. **Rebound limit chains** and **vertical dampers** limit the amount the rate of vertical rebound of the locomotive loco body.

Yaw (longitudinal) dampers control the loco body pitch rate. **Guide rods** control the fore and aft movement between the axles and the bogie frame, while the **link rod** controls the fore and aft movement between the bogies and the loco body.

Primary suspension, located between the axles and the bogie frame, is provided by twin coil springs on the axle journal box fore and aft of the axle line. **Vertical hydraulic dampers** are used to dampen the rebound rate of the

springs. This "Flexicoil" arrangement permits lateral movement of the axle. Longitudinal control of the axle, and the transmission of tractive and braking effort to the bogie frame, is provided by **guide rods** connected between the axle journal boxes and bogie frame. Spheribloc rubber bushes in the guide rods allow the axle lateral movement without undue restriction.

Secondary suspension is also provided by coil springs and vertical hydraulic dampers located between the bogie frame and the locomotive under frame on each side of the bogie. The weight of the loco body is carried by the secondary suspension springs. The "Flexi Float" arrangement of the secondary suspension allows the loco body to move both laterally and vertically within certain limits relative to the bogies.

Bogie layout

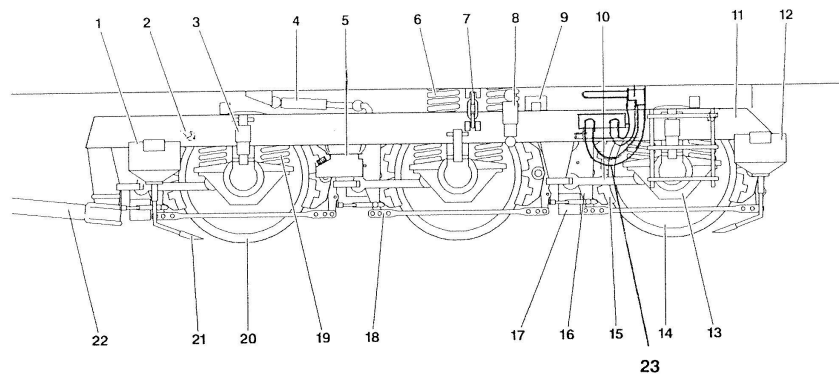

- | | |
|--------------------------------------|--|
| 1 Sanding box | 2 Wheel flange lubrication nozzle |
| 3 Primary suspension damper | 4 Secondary suspension yaw damper |
| 5 Wheel flange lubrication reservoir | 6 Secondary suspension spring |
| 7 Safety chain | 8 Secondary suspension vertical damper |
| 9 Horizontal damper | 10 Wheel set guide |
| 11 Bogie frame | 12 Sanding box |
| 13 Wheel set | 14 Wheel |
| 15 Brake blocks | 16 Brake lever |
| 17 Brake cylinder | 18 Brake rod |
| 19 Primary suspension spring | 20 Wheel flange |
| 21 Sanding pipe | 22 Traction link |
| 23 Anti compounding valve | |

Chapter- 6**SYSTEM DESCRIPTION****6.1 Potential transformer.**

The primary voltage transformer is situated on the converter roof hatch and attached to the pantograph via the roofline. The primary voltage transformer reduces the catenary voltage, approximately 25 kV, to 200 volts AC. A resistor is placed across the primary voltage transformer to provide a reference load.

The output signal is used in three ways;

- 1) Main converter electronics = 4 volt AC
- 2) Catenary voltmeters on the driver's console = 10 volt DC
- 3) Minimum voltage relay.

When panto is raised this potential transformer fed to U meter and U meter shows the OHE supply in drivers cab.

As such we can have an idea of availability of OHE supply before closing DJ and also idea of rising of panto. However our responsibility of seeing panto is not finished, we have to check the condition of panto physically.

6.2 Main Transformer**General:**

25 KV, 1-phase, AC Supply is taken from OHE catenary/ contact wire through pantograph, roof equipment and VCB (DJ). The same supply is fed to charge the " parallel induction transformer" where it is stepped down to different operating voltage.

The tank is filled with transformer oil:

- In order to increase the insulation strength and
- So that the arising heat loss can be dissipated through the circulating oil

The two parallel oil circuits with pumps and heat exchangers are provided

A spy glass is provided in each machine room to check the oil level of transformer oil.

There are 3 secondary winding:

- a. Convertor secondary winding/Traction winding.(4 nos.)
- b. Aux. Convertor secondary windings.(1 no.)
- c. Harmonic filter secondary winding.(1 no.)

ROOF LAYOUT

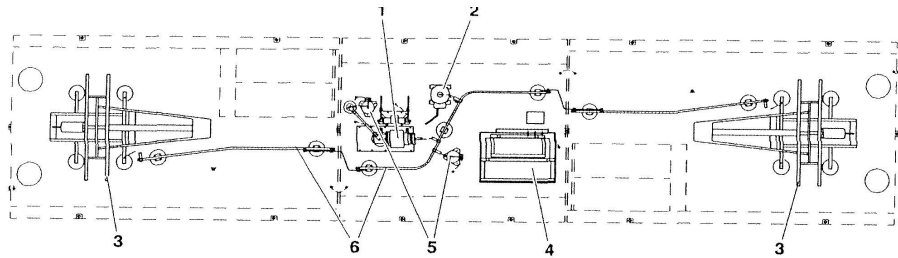

- | | |
|------------------------|----------------------------|
| 1 Main circuit breaker | 2 Potential transformer |
| 3 Pantograph | 4 Resistor harmonic filter |
| 5 Surge arrestor | 6 Roof line |

LIGHTING AND OUTSIDE CONNECTIONS

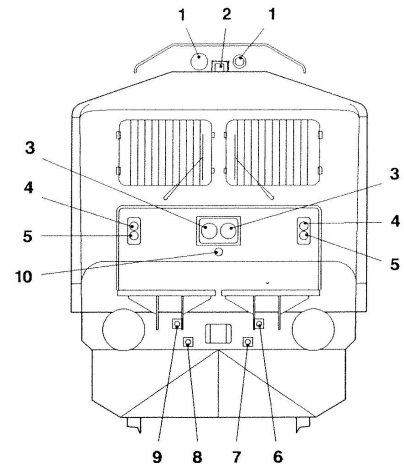

- | |
|--------------------------------------|
| 1 Signal horn |
| 2 Emergency flash light |
| 3 Headlights |
| 4 Marker light, white |
| 5 Marker light, red |
| 6 End cock direct brake (DB, yellow) |
| 7 End cock main reservoir (MR, red) |
| 8 End cock brake pipe (BP, green) |
| 9 End cock feed pipe (FP, white) |
| 10 Coupling, UIC cable |

6.3 Traction Power Circuit (WAG-9 & WAP-7)

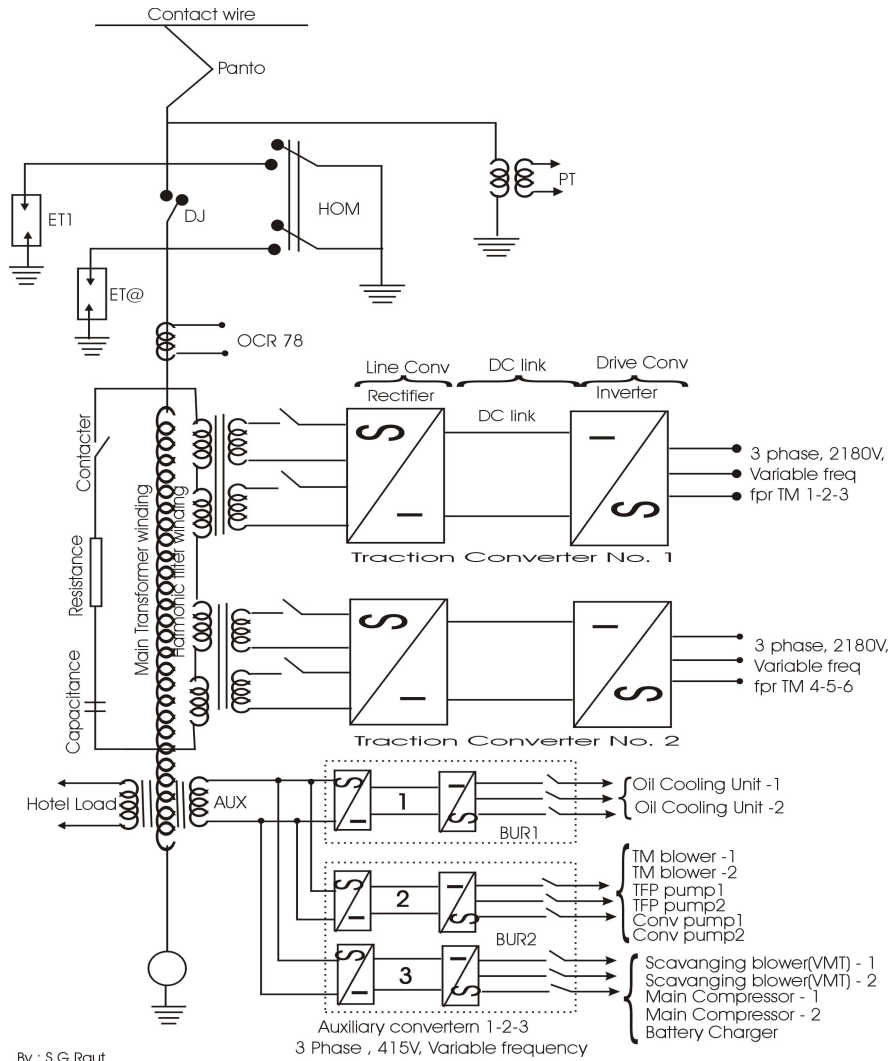

6.3 Traction Power Circuit (WAP-5)

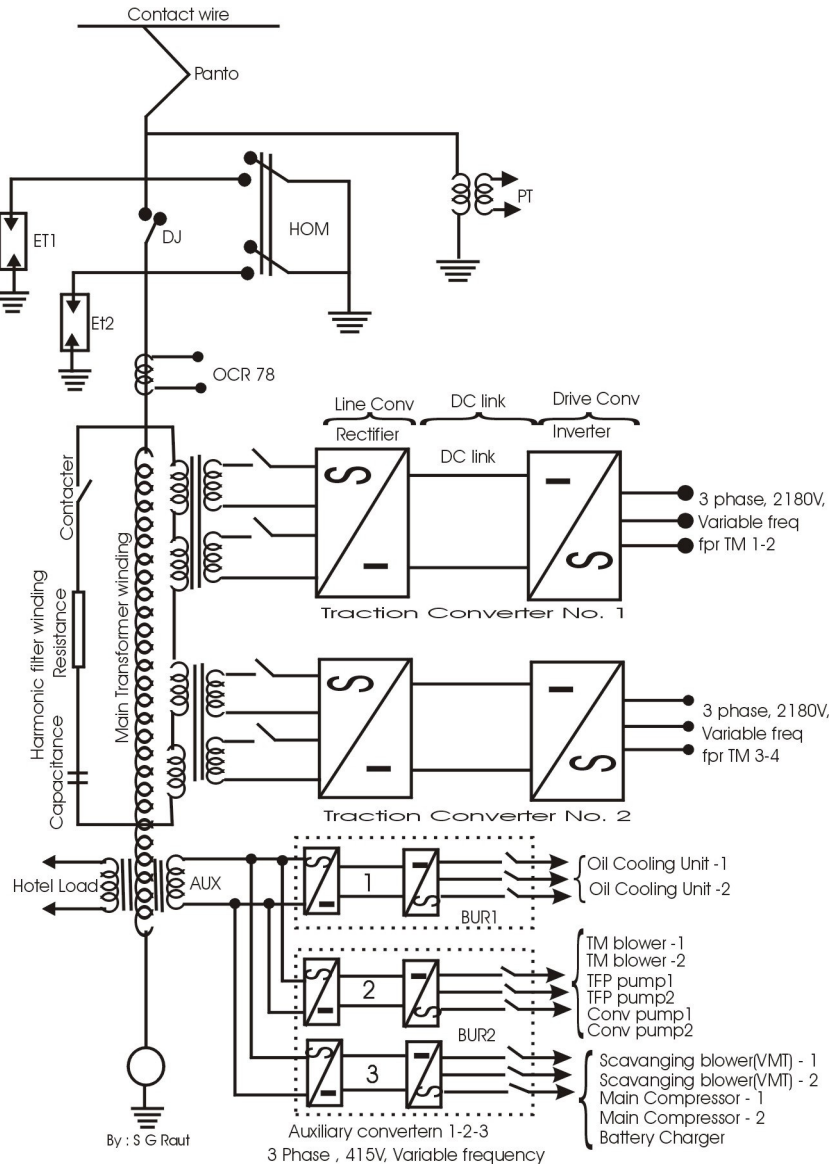

6.3 Traction Power Circuit:

Power from the overhead Catenary is directed to the main transformer, mounted on the locomotive under frame, via the pantograph. The traction circuit is split into two separate circuits after the main transformer.

The traction converters can conduct current from the Catenary to the traction motors to provide propulsion, or can act as in the opposite manner conducting, and rectifying, current from the traction motors to the Catenary. This allows the converter to work in both traction and braking mode. During braking the traction motors act as generators feeding power back into the catenary. The traction converters then act to convert the three phases into single phase for the catenary.

The traction converters provide continuous and automatic control of both speed and torque of the traction motors according to the driver's demand. The converters are controlled by the converter control electronics, and the locomotive central electronics.

Three, 3-three phase asynchronous traction motors are connected in parallel to each traction converter.

6.3.1 Traction Converter: (SR)

Traction converter converts single-phase 25 KV AC supply into 3 phase AC, with Variable Voltage (max 2180 V) and frequency (from 65 to 132 Hz) while traction mode and fed it to traction motor group -1.

As such there are two traction converter i.e. Traction converter-1 for TM 1-2-3 and Traction converter-2 for TM 4-5-6.(In case of WAP-5 , traction converter-1 for TM 1-2 and Traction converter-2 for TM-3-4)

While electrical braking the traction motor works as a generator and fed generated 3-phase supply to Traction converter. This converter now act in reverse manner i.e. it converts 3 phase AC supply into single phase AC supply and fed it to Transformer. Further main transformer steps up this supply and fed back to OHE. In this way 3 phase loco works as a small powerhouse, which generate supply and share the load by feeding it back to OHE.

SR is cooled by two separate oil cooling unit.

The traction converter has three main sub parts:

1) Line Converter 2) Intermediate DC link and 3) Drive converter.

One spy glass is provided on each SR to check the oil level.

6.3.2 Line Converter :(NSR)

The line converter converts the alternating current supplied from the main transformer into direct current (motoring) and forwards this direct current to the intermediate DC-Link. However, it is also able to convert direct current from the intermediate DC-Link into alternating current and to supply this alternating current in turn to the main transformer (braking). Both functions are activated by the traction converter control electronics.

6.3.3 DC Link:

The intermediate DC-Link performs two main tasks. Firstly, it smoothes the direct current that flows through. Secondly, it also performs the storage function, thus covering the peak current demand of the line converter or of the motor. It works as a electrical buffer between ASR and NSR

6.3.4 Drive Converter- (ASR):

The drive converter converts the direct current from the intermediate DC-Link into three-phase current for the drive motors (motoring). Conversely, it is also able to convert the three-phase current generated by the drive motors into direct current for braking. The construction of the motor inverter valve set is identical to that of the line converter. The complete assembly of line converter No.1, DC link and drive converter No.1 is termed as "TRACTION CONVERTER NO.1" which in turn converts 1-phase AC supply of main transformer into 3-phase AC supply with variable voltage and frequency and fed to the 3-phase traction motor.

6.3.5 Technical Data Of Traction Converter

Coolant oil		SHELL DIALA DX
Input voltage	(RMS)	2 x 1,269 Volt
Input current	(RMS)	2 x 1,142 Amp
Input frequency		50Hz
DC-Link circuit nominal voltage(Ud)		2,800 Volt
Output voltage (line-line voltage, RMS)		2,180 Volt
Output current (per phase, RMS)		740 Amp
Output power		2,105 kW
Out put frequency		65-132 Hz

6.4 Traction Motor:

There are total 6 traction motors provided in WAG-9 / WAP-7 loco. TM 1-2-3 are mounted in bogie-1 and fed from traction converter -1 where as TM 4-5-6 are mounted in bogie -2 and fed from traction converter -2. In case of WAP-5 there are 4 traction motors in which, Traction converter-1 fed to TM-1-2 where as traction converter-2 fed to TM3-4.

Unlike conventional WAG-5 /7 individual TM cannot be isolated in this loco only a group isolation is possible. For isolation of TM group one rotating switch No. 154 is provided in SB-1, its normal position is “ Norm”.

In WAP-7 & WAG-9 , the traction motor is forced—air cooled and intended for transverse installation in a 3—motor bogie. The power transmission is effected via a spur—wheel gear. In WAP-5 the TM is fully suspended and connected with gear by hurth coupling by which power is transmitted.

Traction motor is suspended on axle, by axle cap at one end and on link at another end.

To check the oil in gear case one spy glass is provided on gear case.

To monitor the temperature & speed, sensors are provided in the stator assembly.

6.4.1 Technical Data Of Traction Motor:

WAG-9/WAP-7

Type	6FRA 6068		
Kind of motor	6 - poles/alternating current Asynchronous motor, 3-phase		
Cooling	Forced air cooling		
Power supply	Current fed converter		
Temperature recording	2 thermal resistance elements installed in a stator tooth		
OUTPUT P (KW)	Continuous 850	Max.	850
VOLTAGE U (V)	Continuous 2180	Max.	2180
Current Intensity I (A)	Continuous 270	Max.	370
Frequency (Hz)	Continuous 65	Max.	132

WAP-5

Type	6FXA 7059		
Kind of motor	6 - poles/alternating current Asynchronous motor, 3-phase		
Cooling	Forced air cooling		
Power supply	Current fed converter		
Temperature recording	2 thermal resistance elements installed in a stator tooth		
OUTPUT P (KW)	Continuous 850	Max.	1150
VOLTAGE U (V)	Continuous 2180	Max.	2180
Current Intensity I (A)	Continuous 370	Max.	540
Frequency (Hz)	Continuous 65	Max.	80

6.5 Auxiliary Converter:**6.5.1 General:**

The motors used for the auxiliary circuits are 3-phase squirrel cage motors. The cost of maintenance is therefore low. There are total 12 auxiliaries run by 3-phase, 415 V AC supply. This 3-phase 415 V, AC supply is obtained by Auxiliary converter to feed different 3-phase auxiliaries and one battery charger.

The auxiliary circuits are controlled as required. The traction motor and oil cooling blowers run only when required. The control electronics adjusts the blower speeds depending on measured operating temperatures, nominal traction values and speed.

Transformer and traction converter oil pumps work continuously whenever the auxiliary converters are operating.

Auxiliary converter receives single -Phase AC 1000 volts supply from auxiliary winding of main transformer.

This single-phase supply is fed to rectifier module auxiliary converter where it converts into DC supply. This DC supply is fed to DC link to suppressed AC pulses in DC.

The pure DC supply then fed to inverter module auxiliary converter where it converts DC supply to 415V, 3-phase AC supply with variable amplitude of voltage and frequency and then fed to different 3-phase auxiliaries.

There are three, auxiliary converters which get single phase 1000 volts AC input supply from common auxiliary winding and fed 3 phase 415 volt out put to different 12 auxiliaries and one battery charger.

Auxiliary converter-1 is placed in cubicle called BUR-1 situated in machine room no-1 where as aux converter no. 2 and 3 are placed in cubicle BUR-2, which is situated in machine room no. 2

Auxiliary Power Circuit

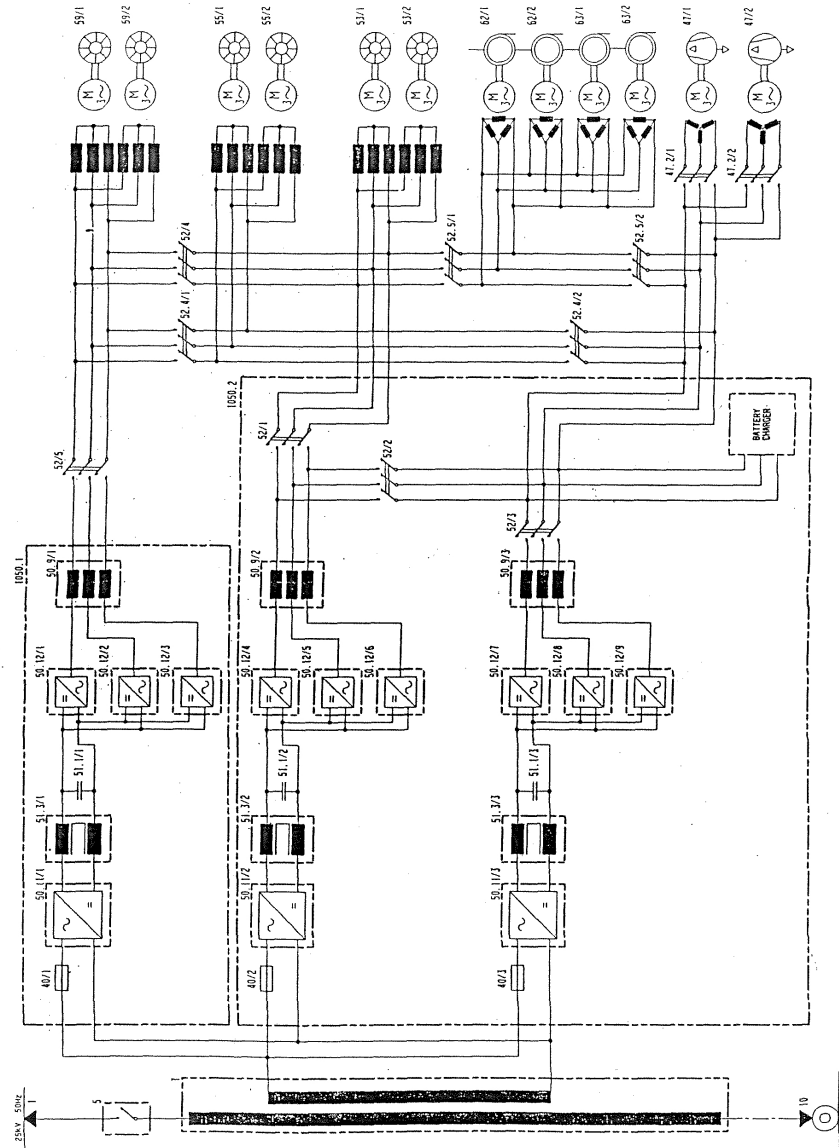

6.5.2 3 phase, 415 volt Auxiliaries

Following 3 phases, 415-volt auxiliaries are provided on this loco, which are fed from Auxiliary converter no. 1, 2 and 3.

Auxiliary	Location	Function	MCB
Load on Auxiliary Converter no.- 1			
Oil Cooling Blower-1 (OCB-1)	Machine Room-1	To cool transformer and SR-1 oil in cooling unit-1 by taking air from roof	59.1/1 In HB-1
Oil Cooling Blower-1 (OCB-1)	Machine Room-2	To cool transformer and SR-2 oil in cooling unit-1 by taking air from roof	59.1/2 In HB-2
Load on Auxiliary Converter no.- 2			
Tr. Motor Blower-1	Machine Room-2	To cool bogie –1 TM group by forced air.	53.1/1 In HB-1
Tr. Motor Blower-2	Machine Room-1	To cool bogie –2 TM group by forced air.	53.1/2 In HB-2
Transformer oil pump-1	Under Truck Below Machine room-1	To circulate oil from TFP to Cooling Unit-1 & back	62.1/1 In HB-1
Transformer oil pump-2	Under Truck Corridor-2	To circulate oil from TFP to Cooling Unit-2 & back	62.1/2 In HB-2
Tr. Converter Oil Pump-1	Machine Room-1 Near SR-1	To circulate oil from SR-1 to Cooling Unit-1 & back	63.1/1 In HB-1
Tr. Converter Oil Pump-2	Machine Room-2 Near SR-2	To circulate oil from SR-1 to Cooling Unit-2 & back	63.1/2 In HB-2
Load on Auxiliary Converter no.- 3			
Main Compressor-1	Under Truck below Machine room-1	To create MR pressure to 10.0 kg/cm ²	47.1/1 In HB-1
Main Compressor-2	Under Truck below Machine room-2	To create MR pressure to 10.0 kg/cm ²	47.1/2 In HB-2
Scavenging Blower-1	Machine Room-1 Near TMB-2	To clean dust from air filters of TMB-2 & OCB-1	55.1/1 In HB-1
Scavenging Blower-2	Machine Room-2 Near TMB-1	To clean dust from air filters of TMB-1 & OCB-2	55.1/2 In HB-2
Battery Charger	Within Auxiliary Converter Cubicle	To charge battery	110 In SB-2

6.5.3 Load Sharing

Generally all the 3 Auxiliary converters are loaded equally, but in case of failure of any converter another converter shares its load. In such condition, frequency of aux. Motor drops from 50 Hz to 37Hz.

Load sharing after isolation of any aux. converter.

Aux. Conv-1 Isolate	Load on Aux.Conv-2	Oil cooling blower 1-2,Tr. Motor blower 1-2 Scavenging blower 1-2
	Load on Aux. Conv.-3	MCP 1-2 , Transformer pump 1-2 Converter pump 1-2 , Battery Charger
Aux. Conv-2 Isolate	Load on Aux.Conv-1	Oil cooling blower 1-2,Tr. Motor blower 1-2 Scavenging blower 1-2
	Load on Aux. Conv.-3	MCP 1-2 , Transformer pump 1-2 Converter pump 1-2 , Battery Charger
Aux. Conv-3 Isolate	Load on Aux.Conv-1	Oil cooling blower 1-2,Tr. Motor blower 1-2 Scavenging blower 1-2
	Load on Aux. Conv.-2	MCP 1-2 , Transformer pump 1-2 Converter pump 1-2 , Battery Charger

Note: -

1. Machine Room blower and scavenging blowers (2+2) are directly supplied and starts as soon as VCB is closed independent of MCE in driving as well as in cooling mode.
2. The oil pump for transformer and converter works continuously during operation of converter.
3. TM blower and, oil cooling blower and scavenging are run as per requirement.

The control electronics adjust the selected stage of measured operating temperature; nominal traction value and speed range lower - moderate – maximum. However, RDSO has issued instructions for the removal of 24 Hz from BUR1 to minimize OCB failure.

6.5.4 Main Compressor 1 & 2

Starting:

For starting the main compressor a spring-loaded switch (BLCP) is provided on panel, 'A' which is having 3 positions.

1. 'OFF' position - For stopping compressors.
2. 'AUTO' Position - Compressor 1&2 will work alternately according to cut in and out of cycle.
3. 'MAN' Position - Compressors work continuously irrespective of MR pressure. This is spring-loaded position.

Auto Position

1. Air pressure goes below 8 Kg/Cm² :
Only one compressor start alternately up 10 Kg/Cm².
2. Air pressure goes below 7.5 Kg/Cm².:
Both compressors start till pressure reaches to 10 Kg/cm²

3. Air pressure goes below 5.6 kg/cm²:
 “Low pressure, main reservoir” message appears on the screen with priority-1 fault along with LSFI indication. No TE/BE is possible till MR pressure reaches to 6.4 Kg/Cm². Both compressors will start till MR pressure reaches to 10 Kg/Cm²
4. After getting the start command, compressor starts but it takes 25 seconds to ramp up and unloading and start actual pumping there after. During this delay, pressure drops by 1 to 1.5 kg/cm². So if we sees the gauge cut in cut out setting will be appear as 7 to 10 kg/cm² instead of 8 to 10 kg/cm².

6.5.5 SINGLE - PHASE 415 V/110 V AUX. CIRCUIT:

The auxiliary transformer is located in cubicle-1(HB-1) and supplies following systems with 1-phase power.

This circuit is independent of CE and all these auxiliaries work in Driving as well as cooling mode and start as soon as VCB closed.

Auxiliary	Location	Use	MCB
Single phase 415 Volts			
Machine Room Blower-1	Machine Room-1	To cool machine room by ducting and limit the temperature of control electronics parts below 70 ^o C	54.1/1 In HB-1
Machine Room Blower-2	Machine Room-2	-do-	54.1/2 In HB-2
Scavenging Blower for Machine room Blower-1	Machine Room-1	To clean dust from air filters of Machine Room Blower-1	56.1/1 In HB-1
Scavenging Blower for Machine room Blower-2	Machine Room-2	To clean dust from air filters of Machine Room Blower-2	56.1/2 In HB-2
Heater Element	In Both cab. Inside Desk	To deliver heat for keeping the cab warm	69.62 In HB-1
Single phase 110 Volts			
Crew Fan: 4 nos.	2nos. in Both cabs	Crew ventilation	69.71 In HB-1
Cab Ventilation Blower- 2 nos.	One in Both cab Inside Desk	To expel heat of heater element into the cab.	69.61 In HB-1

6.6 COOLING CONCEPT

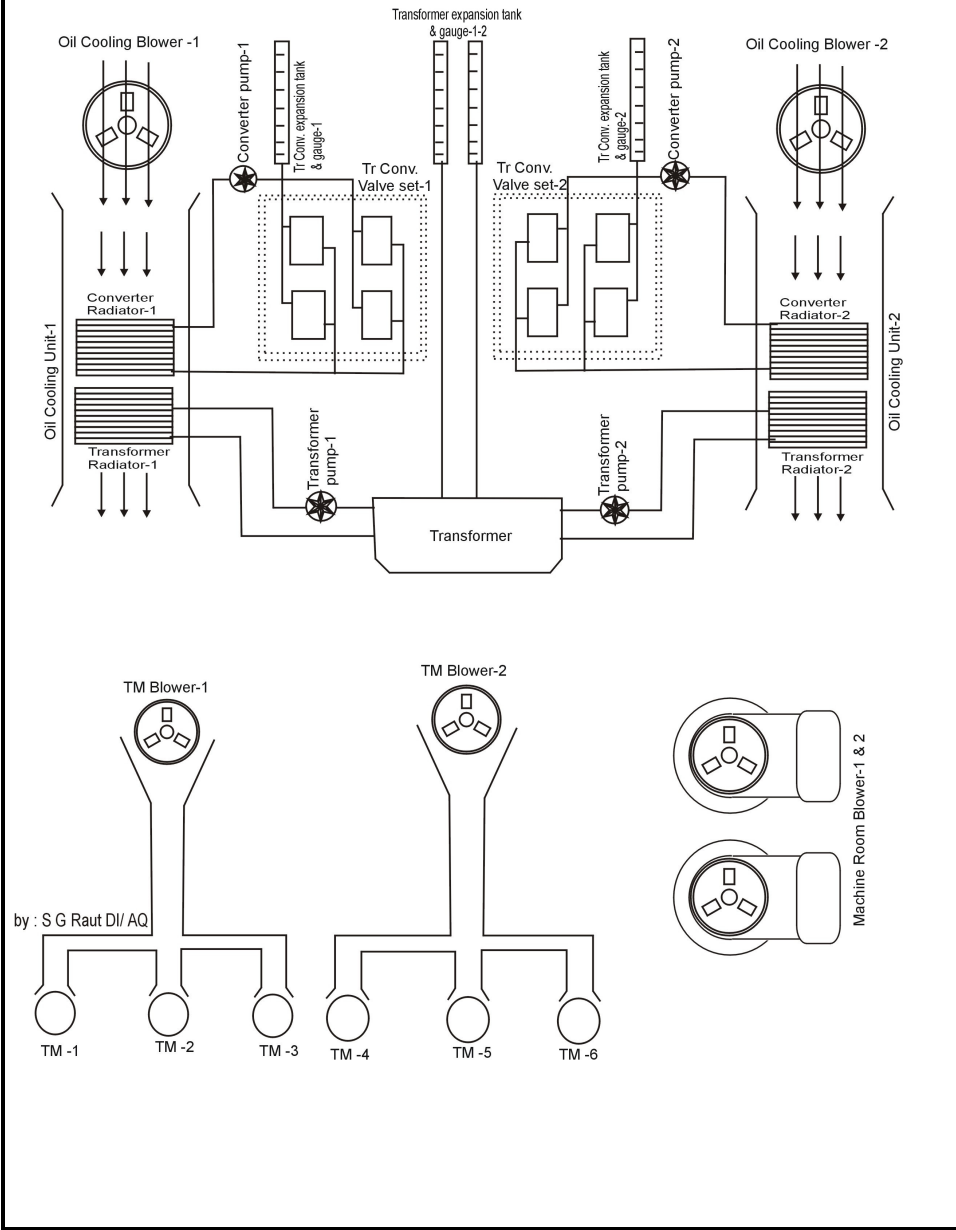

6.7 Harmonic Filter:

Line harmonic filter is connected with primary winding of main transformer which consist of resistances and capacitor. This harmonic filter reduces/suppressed the high frequency harmonics to avoid disturbances in signaling.

If the harmonic filter get bypassed by the system, the speed of the loco / train will be automatically restricted up to max 40 KMPH by CE.

6.8 Battery

In ABB loco NiCD Battery is used. There are total 78 cells in the batteries which are placed in 2 boxes at either side of the locomotive. Each box contains 39 cells and each battery has 3 cells. Capacity of battery is 199 A-H and output is 110 V. To charge the battery, one battery charger is provided with circuit breaker no. 110 situated in SB2. Main switch for battery is 112 which is placed in a box provided near battery box no. 2. For control circuit supply 1 MCB no. 112.1 is provided in SB2. To show the battery voltage UBA is provided in either cab.

Note:-

1. If battery voltage is 92 V for more than 30 seconds, P-2 Fault will appear on the screen.
2. If charging current is reduced by 10 A, P-2 fault will appear on screen.
3. If battery voltage is reduced below 82 V, P-1 message with shutdown of loco will appear.
4. If cab is activated and panto is lowered than 10 minutes CE will switch off automatically.
5. Loco CE get power supply directly from battery and can supply upto maximum 5 hours.
6. For machine room light power supply is given directly through MCB 327.4.

Technical Specification:

Cell model	= SBL-199
Cell type	= Nickel/Cadmium
Number of cells per battery	= 3
Number of batteries per battery box	= 13
Number of battery boxes	= 2
Total nominal capacity	= 199 Ah
Nominal voltage of each cell	= 1.4 V
Total battery voltage	= 1.4 x 3 x 26 =110 V

6.9 Brake System:

There are 5 types of brakes available on this loco.

1. Automatic Train Brake (Pn)
2. Direct Brake (Pn)
3. Parking Brake (Spring Loaded)
4. Anti Spin Brake.(Pn)
5. Regeneration Brakes.(Elect)

Note: All the brake system functions are monitored by brake electronics and if there is any wrong configuration, the brake electronics do protective action along with P-1 message on screen. One circuit breaker is also provided in SB-2 for this brake electronics. In case of failure of brake electronics, crew should check this MCB.

6.9.1 Automatic Train Brake (A-9)

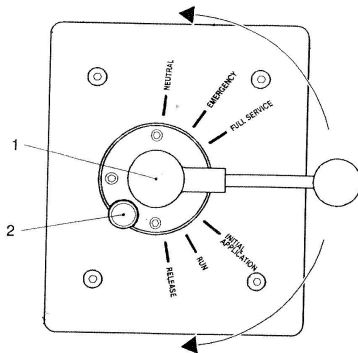

In both the cabs one Drivers Brake Controller (DBC) is provided which is the electrical switching equipment.

The function of the driver's brake controller is to generate a variable voltage code in accordance with the position of the controller handle and to perform a number of ancillary electrical functions. A pneumatic valve is incorporated to provide a pneumatic emergency brake function in addition to the electronically controlled emergency brake.

This brake is utilized for charging and discharging the B.P. Pressure to apply/release train brake and also loco brakes in conjunction working.

This valve has following 6 positions.

This A-9 is remaining active in active cab only. Once the BL key is rotate from D to OFF, this handle will not functions, but its emergency position will act.

Handle position	Pressure (kg/cm ²)
Release	5.4 ± 0.05 (LPO)
Running	5 ± 0.05
Initial Application	4.60 ± 0.05 Variable
Full Service	3.35 ± 0.10
Emergency	0
Neutral	0

B. P. CHARGING SYSTEM

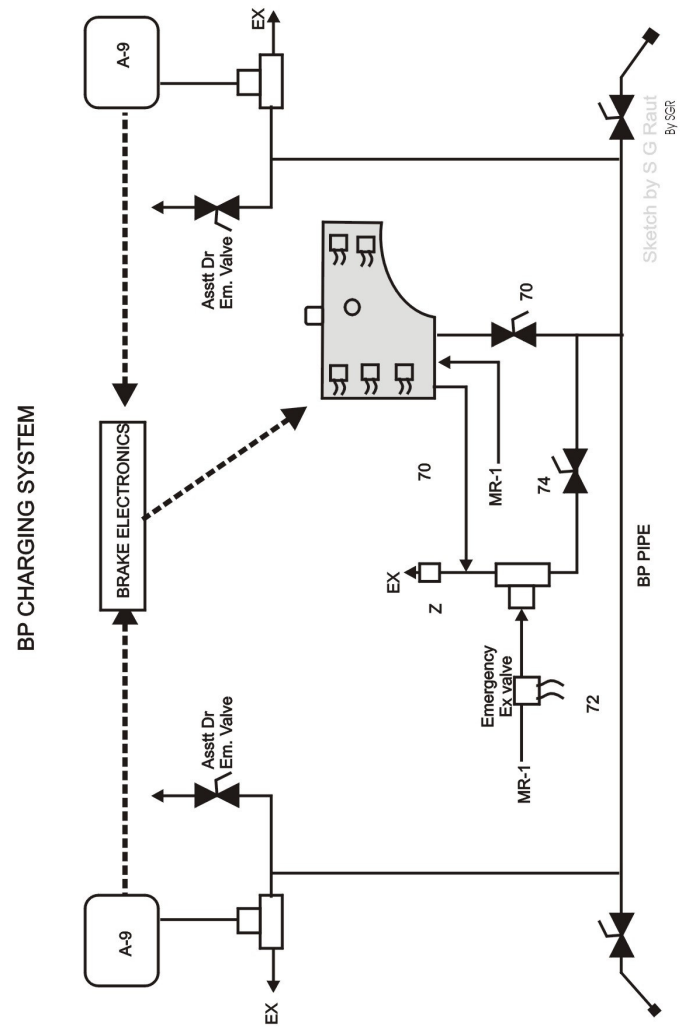

Running:

When the handle of the brake controller is placed in the 'Running' position, the 'Running' E.P. valve energised the E-70 valve and allow the 5 kg / cm² pressure to go in brake pipe via cock no.70.

As such A-9 gives electrical command to valve E-70 and E-70 allows 5 Kg / cm² pressure to enter in BP.

The system for charging the brake pipe is fully self-maintaining.

Note: coc 70 performs the function of A-8 (L&T) coc as in WAG-5/7 locos). This coc is provided with electrical switch due to which its position is monitored by brake electronics and if there is wrong configuration of coc, concerned P-1 message appears on the screen.

Braking:

When the handle of the brake controller is placed in a apply position the control circuits will produce the pressure to give the relevant brake pipe pressure.

The brake signal from the brake controller causes the control pressure to fall to the level demanded by the particular brake code which in turn causes the Air from the brake pipe now flows past to atmosphere through E-70 valve. The brake pipe pressure is then held constant at a reduced level, which corresponds to the particular braking requirement, against any normal leakage by the self-maintaining feature.

Emergency:

When the handle of the brake controller is placed in the EMERGENCY' position one of the cam operated switches within the controller opens to cut off the power supply to all E.P. valves of E-70, except the 'Isolate' E.P. valve which is already de-energized. At the same time the pilot valve in the driver's brake controller opens venting the operating air from above the piston in the emergency exhaust valve located in the driver's cab. This valve then opens to vent the brake pipe direct to atmosphere at the emergency rate.

In addition to direct exhaust as all the electrical supply switched off the 'Release' and 'Application' E.P. valves are de-energized causing the valve E-70 lifts and therefore vents the brake pipe to atmosphere. In emergency, brake of 2.5 kg/cm² is applied through C3W valve.

Neutral:

When the handle of the brake controller is in the 'Neutral' position the cam operated switches within the controller cut off the power supply to all the E.P. valves (except 'Isolate' E.P. valve which is already de-energized) as for the 'Emergency' position.

Release:

When the handle of the brake controller is held in the spring loaded 'Release' position, the 'Full Bore' and 'Running' E.P. valves (of E-70) are energised. In this condition the system operates as described for the 'Running' condition, except that the 'Full Bore' E.P. valve is energised. This valve allows a low-pressure overcharge in BP pipe.

Low pressure over charge is achieved by raising the normal brake pipe pressure of 5 kg/cm² to a pressure of 5.4 kg/cm² and holding this for a limited period after which the overcharge is arranged to bleed down at a prescribed rate.

The pressure of 5.4 kg/cm² in the brake pipe is held for a short period by an electronic timing device on the low-pressure overcharge circuit board. At the end of this period the 'Low Pressure Overcharge' release E.P. valve is de-energised in a controlled manner which thus reduces the pressure in the control reservoir and hence the brake pipe at a predetermined rate towards a level of 5 kg/cm².

Even overcharging up to 5.4 Kg/Cm² for short time and normalized with restricted rate, there will be no brake binding in load as overcharging feature of DV will prevent DV to overcharge.

Note:

- The handle of A-9 can be remove and insert in neutral position and can be locked by locking device.
- If the electronic brake control system fails, a priority-1 message display on the screen and an emergency brake is triggered.

6.9.2 Direct Brake (SA-9):

To apply loco brakes, Drivers Direct air Brake Valve (SA-9) is provided in both the cabs. The operation of this system is near about same as in case of WAG-5/7. But unlike WAG-5/7 there are no cocks on inlet as well as outlet pipes of Drivers Direct air Brake Valve (SA-9). Instead of cock the EP valves (pilot valves) are provided which keep the Drivers Direct air Brake Valve (SA-9) in service only in active cab automatically.

As a preventive measure, the handle of Drivers Direct air Brake Valve in rear cab should be kept in release position.

Unlike WAG-5/7, separate relay valves are provided for loco brakes through Drivers Direct air Brake Valve and loco brakes through conjunction working. So possibility of total brake failure due to relay valve failure is eliminated.

The Drivers Direct air Brake Valve has two positions; APPLY and RELEASE

Apply:

When the driver's control handle is moved to the 'brake on' position, air from the main reservoir admits in the out let pipe which (3.5 kg / cm² max) is further connected to braking relay valve 58. This pressure operates the relay valve so relay valve again allow the MR pressure waiting at its port to the brake cylinders through 2nos of DCVs and bogie isolating coc. Brake cylinder pressure can be seen in the gauges provided in both the cabs.

Release:

When the driver's control handle is moved towards the 'release' position, it isolates the main reservoir pressure from the relay valve. Simultaneously, allows the pressure from the relay valve to escape to atmosphere through its exhaust port. As the pressure from relay valve get exhausted, relay valve further disconnect the pressure flow from MR to brake cylinder and simultaneously the pressure of brake cylinder get exhausted to atmosphere through exhaust of relay valve.

Any desired releasing stage for the brake cylinder pressure may be obtained according to the position of the driver's control handle.

The direct brakes are used to apply loco brakes. In WAP5 direct brake apply on wheel disk with the pressure of 5 Kg/cm² whereas in WAG-9/WAP-7 it apply on wheel tyre as conventional loco with the pressure of 3.5 Kg/m². The brake handle remains active only in active driver Cab.

Start/running interlock (i.e. regression of TE / BE) is initiated when the speed of loco is above 10 KMPH and BC pressure share in gauge by 0.6 kg/cm² and above..

For isolation of brakes of particular bogie, bogie coc are provided. COC for bogie -1 is provided below machine room -1 above MCP-1 where as COC for bogie -2 is provided below machine room -2 above MCP-2

Brake cylinder gets supply from following:

1. From SA-9 through C-2 (58)relay valve (3.5 kg/cm²)
2. From C3W DV in conj. working through C-2(57) relay valve (2.5 kg/cm²)
3. From Anti spin device (Wheel slip) (0.6 kg/cm² to 1.0 kg/cm²)
4. From blending valve (DBR cut off) : in proportion

To separate these different pressure paths different DCVs are provided in the path.

Loco Brake system

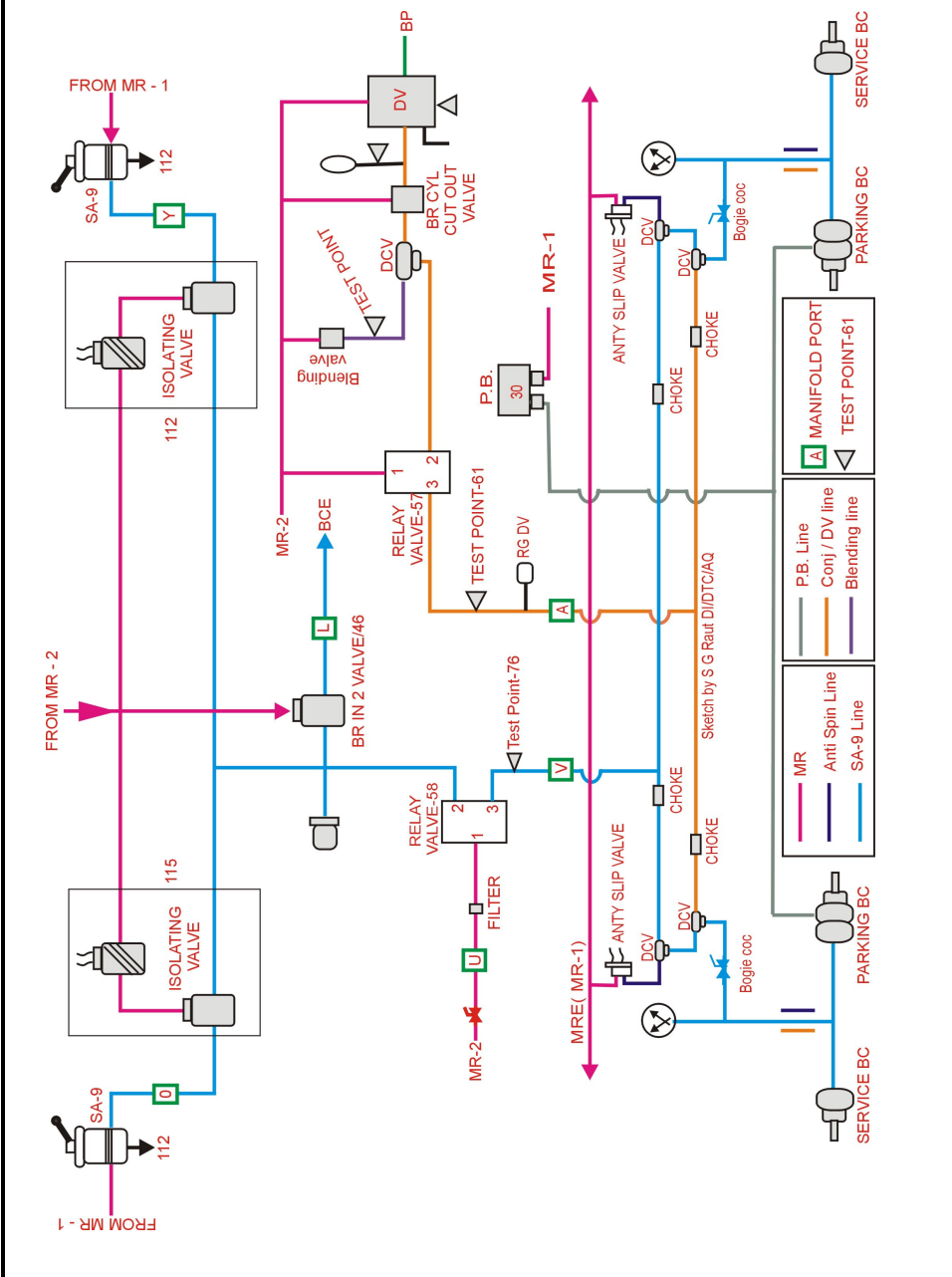

6.9.3 Anti Spin Brakes:

The principal of the anti-spin brake is to provide the traction equipment, with means to obtain a rapid yet light brake application to the driving wheels. The friction thus generated between the brake shoes and the tyres immediately absorbs the torque, which is in excess of the value that can be absorbed by the normal adhesion between the tyre and railhead. The net result is to prevent any increase of existing wheel slip.

The principal advantages are that the slip is prevented or controlled, so avoiding the possibility of damaging the traction equipment, and at the same time it normally enables the traction power to be maintained so improving and simplifying the control of the locomotive when operating under conditions which may cause wheel slip.

The anti-spin brake can give an improved adhesion condition between the rail and tyre, due to the cleaning effect of the brake shoe when used with 'On tread' braking.

A further important advantage of the anti-slip brake is that its use often enables a reduction in the use of sanding.

This device is provided on each bogie behind MCP.

The automatic anti - spin protection is initiated as soon as the ratio between effective tractive/braking effort and requested tractive/braking effort is less than 0.5

As required, one or more of the following actions is/are initiated:

- Sanders start
- LSP glows
- TE/BE difference is reduced by control electronics.
- If necessary required braking force is given to wheel by applying loco brakes by control electronics- you can see that BC needle ups and down. (Which is limited to 0.6 kg / cm² to 1.0 kg/cm²)

Note :

- If anti spin brakes are not applied at the time of wheel slipping, then wheels will get off loaded and to avoid further spinning, CE will reduce tractive effort. This will affect the hauling of load
- When train is in motion with speed more than 10 KMPH, Start/Run interlock get activated if BC pressure rushes above 0.6 kg / cm² and TE becomes 0.

On run during anti spin brakes, 0.6 kg / cm² to 1.0 kg/cm² pressure rushes in brake cylinder. So as per above, due to this 0.7 kg/cm² pressure TE get reduced to 0 affecting haulage of load.

- Presently as per RDSO's instructions anti spin brakes are isolated on the locos to avoid TM failure.

6.9.4 Brakes Through Blending Valve:

If train is running in regenerative (DBR) mode and suddenly regenerative braking gets cut off automatically due to internal fault or VCB tripping, to compensate regenerative braking, blending valve send the MR pressure in the brake cylinder in proportion. This pressure activates the relay valve (57), further this relay valve allows MR pressure into BC (See figure of loco brake system).

6.9.5 Synchronous loco brakes:

When ever BP pressure drops below its pre determined value (i.e.5 kg/cm²), distributor valve gets activated and allows MR pressure to activate relay valve (57), further this relay valve allows MR pressure to rush in brake cylinder (2.5 kg/cm²). Like this, when BP restores , DV gets balanced and releases the brakes accordingly.

6.9.6 Parking Brake

In 3 phase loco, hand brakes are not provided. For parking the loco a new type brakes are available on this loco, called parking brake. The great feature of parking brake is that, it remain applied to indefinite time as per your requirement in absence of air pressure. Its function is just opposite to that of conventional brakes. i.e. it remain release when there is 6 Kg/m² pressure in parking activator and get applied when pressure exhausted below 3.8 Kg/m² in parking activator. But the brakes are applied through the same brake block of conventional loco brakes.

Parking brakes are provided on Wheel No.2-6-7-11 (WAG-9/WAP-7) and on wheel no. 1-4-5-8 in WAP-5 loco.

Applying Parking Brake

1. Press push button BPPB ('A' panel), a red lamp illuminated in it. Due to which 6 Kg/m² air in parking activator get exhausted and the PB gauge show '0' kg/m² which indicates the application of P.B. (this is possible only when CE is ON)

OR

2. Press 'Apply' push button on parking brake valve solenoid 30/22, BPPB red lamp will glow, P.B. pressure gauge show '0' kg/m² and PB get applied. (This is possible when there is MR / AR pressure in the loco and lamp will glow if CE is ON)
OR
3. When 'BL' key is moved from 'D' to ' OFF ', parking brakes get automatically applied through control electronics. BPPB will not be illuminated since CE in OFF but P.B.gauge will show "0" kg/cm²

Releasing Parking Brake:

1. Press BPPB illuminated red button once red lamp will get extinguished and 6 Kg/m² pressure enter in parking activators which can be seen in PB gauge indicating that PB are released
OR
2. Press "Release" push button on parking brake solenoid 30, BPPB red lamp will extinguish, air will be admitted in parking activator and gauge will show 6 Kg/cm² pressure
OR
3. Pull "parking brake release spindle" provided on parking brake cylinder on wheel No.2,6,7,11. (for WAP-7/WAG-9) and on wheel no. 1-4-5-8 (for WAP-5 locos.)

The lock of PB will open and piston return to release position due to re-setting spring at that time. 'KHUT" sound will be heard.

Note:

- If PB are released through manual lever, BPPB will not extinguish in Energized loco and driver may get indication of application of PB and throttle will not respond, in such case press BPPB to release PB even though PB are released manually.
- Ensure releasing of PB by physically shaking the brake block.
- in dead loco if there is no air pressure even though the PB will remain in applied condition , but once the brakes get released , then PB cannot be applied again until the loco takes on pressure. So, while shunting the dead loco and stabling there after, this fact should be kept in mind and loco should be secured properly by wooden wedges as local hand brakes are not provided in the loco.

Locking Of Parking Brakes:

- Parking brakes can be locked in applied or in release condition for this purpose locking arrangement is provided on release and application plunger of solenoid valve 30.

- If plunger is pressed and then rotate, it will be remain in that condition until you unlock it by again rotating it and taking out the plunger out side.
- For locking the parking brake, follow the instructions of the division if any; otherwise don't lock the parking brakes.

6.9.7 FAILURE OF BRAKE ELECTRONICS:

Whenever brake control electronics get failed a priority-1 message appear on the screen with emergency brake application. One circuit breaker is also provided in SB-1, if this circuit breaker is tripped same symptoms will appear.

6.9.8 Regenerative Braking:

This is an electrical braking system in which brakes are applied on loco without physical application or brake block failure.

1. Brake block does not apply on wheel so wheel and brake block wear is eliminated.
2. Reliable braking.
3. Smooth controlling.
4. Energy generated during braking is fed back to OHE i.e. it works just like a small power station and helps in energy conservation.
5. Braking is available up to 0 KMPH.

When throttle is put to BE side, traction motor work as generator and generates 3 phase, AC supply which is converted into DC supply by driver converter and fed to line Converter through DC link. In line converter this DC supply is again converted into single phase/AC supply in such a way that it induces supply equal to line voltage in main transformer through converter, which later on fed to OHE through VCB and pantograph.

At the time of Regenerative braking, the TE / BE meter deviates down ward in RB mode.

- If the RB fails during braking operation the independent loco brakes automatically takes over its function in proportion to RB force through blending valve.
- Even if the RB and Pn brakes applied together due to fault in the system, excessive braking of loco is avoided because the anti spin slides control system reduced the electrical braking effort.
- You can use the regenerative braking from full speed to '0' speed.
- As train loco can be stopped only by using regenerative braking, there is a possibility of non Application of loco brakes, here one thing should be noted that loco can be stopped but cannot be held by regenerative braking. So, don't forget to apply loco /train brakes at halt/stop.

- As already explained it feeds back to OHE during regeneration, so, Use RB as more as possible and generate the energy.
- Also note the readings at the time of CTO & CHO to calculate energy conservation by you.

6.9.9 An Emergency Braking Operation

Emergency brakes will apply through brake electronics when:

1. Response from the Vigilance module
2. Permitted maximum speed being exceeded
3. Moving of the driver's brake handle to position EMERGENCY [automatic train brake]
4. Actuation of the emergency brake cock on the assistant driver's side
5. Actuation of the emergency stop push button on the panel A
6. Failure of the electronic brake control system
7. Train parting

Note :

The emergency stop button is only active in the activated driver's cab. However its function is not dependent on the speed of the locomotive. When the emergency stop button is pressed, the VCB opens and the pantograph is lowered along with BP drop and TE/BE "0".

Emergency braking is actuated directly in all cases and is not controlled by the MCE. However, the MCE responds to emergency braking by reducing tractive effort to 0. If an emergency braking operation is triggered in multiple operation, it is transferred to the slave locomotive also.

6.10 Miscellaneous

6.10.1 Pantograph:

Two pantographs are provided on either end of loco. Design of pantograph is same as other AC locos. For raising and lowering of pantograph one switch 'ZPT' is provided on panel 'A' having 2 positions, UP and DOWN.

When we press switch down ward (i.e position UP) and release - panto will up.

When we press switch upward (i.e position DOWN) and release - panto will lower.

Note: The rear panto will rise automatically.

Selection Of Panto:-

Panto selector switch is provided on Pneumatic Panel in machine Room

Position:

- Auto** - Normal position (only rear panto will raise)
I - Panto of Cab-1 will raise (2 will isolate electrically)
II - Panto of CAB-2 will raise (1 will isolate electrically)

For isolation of both panto pneumatically, there are two COCKS provided on Pn. Panel. PAN-1 & PAN-2. Normally these coc should be opened (Horizontal). For isolating particular panto keep that coc on closed position (i.e Vertical)

One circuit breaker (127.12 Circuit breaker Pantograph, VCB Control) is provided for panto circuit in SB-1 cubicle.

Key IG-38 is provided on pneumatic panel to control the air pressure to Pantographs. For air passage to pantographs this key should be kept ON (horizontal)

6.10.2 Auxiliary Compressor: - (MCPA)

The auxiliary compressor is used to raise the pantograph. While the control Ckt. Is switched 'ON, the auxiliary compressor controlled by Pn switch start automatically (independent of MCE) till the pressure reaches to 6 Kg/cm². Auxiliary compressor has one drain coc on pneumatic panel. Normally this coc should be horizontal to pipe line (i.e. closed)

6.10.3 Main Reservoir:

For shortage of compressed air pressure MR are provided on this loco. In WAP-7 & WAG-9 loco, Two MR and one AR is provided in machine Room in vertical manner. Capacity of MR is 450 liters. Drain coc is provided below each MR, which can be operated from machine room. In WAP-5 MR are located in under truck and each MR having capacity of 240 liters.

In dead loco AR is charged by BP pressure of Live loco provided that coc 47 should be in open condition. This AR pressure is utilized for conjunction loco braking and Parking brakes.

6.10.4 Memotel (Speedometer)

For indicating the speed of the loco, memotel type speedometer is provided in both the cab. Speed is indicated by both needle as well as LCD screen of SPM.

For Data entry one push button "A" is provided on SPM

When push button 'A' is pressed repeatedly following function done. (8 digits) in sequence.

1. Speed : kmph
2. Time : HH:MM:SS
3. Date : DD:MM:YY
4. Distance covered :Km
5. Encoded fault message : -----

Aprox 10 seconds after push button 'A' is released time or speed is displayed automatically.

6.10.5 Sanding:

Sanding is done automatically on leading wheels when

1. Pressing 'foot switch' of sander.
2. Anti spin device activated.

Note :

Don't press PSA continuously, but press and release it. Continuous sanding is not possible, If PSA pressed continuous for 1 minute, then dead mans penalty brakes will apply. 10-12 sec pause is required between two operations of PSA.

6.10.6 Control Electronics [Micas-S2]

All functions of the locomotive are controlled by the control electronics. It takes the form of bus stations with processors.

The bus stations communicate with each other via fiber optic Cables which are resistant to the effects of Electro Magnetic Interference [EMI] The diagnostic equipment comprises a diagnosis computer with monitor and keyboard in the driver's cab. This provides an effective support for the duties of the locomotive driver and maintenance personnel.

6.10.7 Active functions with deactivated driver's cab

While the cab deactivated [key switch in position 'O'], the following functions remain operative.

1. MEMOTEL functions
2. Catenary voltage display
3. Emergency brake cock on assistant driver's side
4. Cab and desk lighting
5. Windshield wipers
6. Fault display screen
7. Marker lights switches
8. Cab venting and heating
9. Crew fans
10. Hand lamp socket

6.10.8 Resetting of MCB

Sometimes MCB trips momentarily without any equipment failure. Drivers should try to reset MCB once. While resetting ABB make MCB, resetting screw below the respective circuit breaker turns to horizontal position from initial vertical position. This screw should be turned to vertical position first and then, MCB should be reset by lifting it's handle.

For resetting MG make MCB, handle should be pulled first downward towards offside and then in upward direction towards on to reset the MCB, otherwise the MCB will not hold.

If it is needed to trip any MCB, trip it with proper procedure i.e. by rotating screw or by pressing tripper knob provided on MCB. Don't trip any MCB directly and in VCB closed condition.

6.10.9 Flasher light

1. Automatic flasher light system is provided
2. One additional flasher light unit is provided in cab at Asstt side, ensure that switch provided on it is at ON
3. To switch on the flasher rotate the switch provided on panel –C
4. Note that flasher glows only when CE is ON or in cooling mode.
5. If on line CE gets off and at the same time if flasher is required then, switch ON it in cooling mode.
6. Note that in panto's down condition, CE remains ON only for 10 minutes after that CE will get off automatically. So, in such cases (like accident), flasher should switch ON in cooling mode.

Testing of automatic flasher light

1. In energize loco, ensure that BP is 5 Kg/Cm² and Set the reverser as per requirement.
2. Drop the 0.6 to 1.0 Kg/Cm² BP for 1 minute by opening ALP's emergency brake valve or by opening BP angle coc.
3. Ensure the following indications
 - ACP message of P-2 will appear on screen.
 - LSAF will glow.
 - Buzzer will sound.
 - BPFL light will flicker.
 - Flasher light will flicker.
4. Recharge the BP by closing BP angle coc or ALP's emergency brake valve, all above indication will disappear, acknowledge the fault by BPFA.
5. Apply A-9 to minimum reduction and full service and release, auto flasher light should not glow. If during normal operation of A-9 auto flasher light glows or if it does not glow during above testing, Inform the TLC/TRS staff.

6.11 KNORR's Computer Controlled Brake System

In some WAG-9 locos KNORR type brake system is provided which is different from conventional brake system of WAG-9 locos.

In conventional loco, loco get failed in case of brake electronics failure. But in this loco, block section can be cleared by 10 KMPH in case of failure of brake electronics.

CHANGES IN CAB**1) Pilot lamp panel**

One panel of 6 pilot lamps is provided beside panel-C which is as under:

- a) **Exclusive Flow:** This is a Red colored pilot lamp, glows when MR pressure is less.
- b) **PCR open:** This is a Red colored pilot lamp, glows when BP pressure is less.
- c) **PER action:** This is a Green colored pilot lamp, glows when PTDC (Pneumatic Time Dependent Control) is in service.
- d) **EAB fail:** This is a Yellow colored pilot lamp, glows when brake electronics failed and PTDC in service.
- e) **P-16 action:** This is a Green colored pilot lamp, glows when DV is isolated.
- f) **SIFA cut off:** This is a Yellow colored pilot lamp, glows when coc 74 is closed

2) Changes in Auto brakes and Direct Brakes:

In case of conventional system, A-9 / SA-9 handle has to be operated from left to right, but in this system handle has to be operated forward and backward like throttle. Both valves are provided on left side of loco pilot on control stand.

a) SA-9 Direct Brake:

SA-9 has two positions; Applied and Release.

One spring loaded clip called " Bail Ring "is provided below the handle of SA-9. If this clip pressed and released, synchronized brakes get released very fast where as brakes get released gradually if PVEF is pressed.

b) A-9 Auto brake:

A-9 handle can be locked or unlocked in FS (Full service) position by a key provided in each cab and coupled with a chain. Non-driving cab A-9 is kept on FS-locked condition where as driving cab A-9 is kept in RUN condition. While clearing loco as dead both A-9 are to be kept on FS-locked condition. A-9 handle has following 5 positions.

- i) **REL-Release:** In this position BP pressure is over charged to 5.5 kg/cm² and drop down automatically after some times with restricted flow to 5.0 kg/cm². This position is used for quick releasing of BP.
- ii) **RUN:** This is the normal position of A-9 on which BP is charged to 5.0 kg/cm². At the time of recharging after application, BP is overcharged by 0.2kg/cm² at this position for short time.
- iii) **MIN.(Minimum Reduction):** BP pressure remains 4.5 kg/cm².
- iv) **FS (Full Service):** BP pressure drops to 3.0 kg/cm². A-9 handle can be locked or unlocked in this position.
- v) **EMER. (Emergency):** BP drops to zero kg/cm² on this position.

c) Mode switch: One rotating switch called mode switch is provided in each cab below SA-9 valve. This is spring-loaded switch and can be operated by pressing downward. This switch has following 4 positions.

- i) **HLPR:** While using loco as banker, this switch should be kept at Help position on this mode in addition to ZBAN at ON.
- ii) **TRL (TRAIL):** In non-driving cab (SU / MU), this switch should be kept on TRL position.
- iii) **LEAD:** In driving cab (SU / MU), this switch should be kept on LEAD position, then BP will be charged 5.0 kg/cm².
- iv) **TEST:** In this position BP leakage test is done. When this switch is kept on TEST position, Loco brakes get applied. This switch should be kept on lead position immediately after testing.

d) Pneumatic Time dependent Control (PTDC):

In this loco SA-9 and A-9 are governed by brake electronics. In case of failure of brake electronics train can be worked by max.10KMPH by PTDC. This is provided in each cab near A-9 / SA-9 and has following 2 positions.

- i) Release and ii) Apply.

PTDC is having one coc, which should always be in open condition.

PROCEDURE of clearing block section by using PTDC:

- Bring throttle to "0"
- Open the DJ, Lower the panto and switch OFF CE.
- Trip the MCB 127.7 (SB-2) and ensure that MCB 127.15 (SB-2) is in ON condition.
- On Pneumatic panel, Close PB-BUS cock & PER-COS from horizontal to vertical position.
- Keep A-9 of working cab on RUN.
- If BPFA is glowing, then acknowledge the fault.
- Switch ON to CE and raise Panto, close VCB (DJ)
- Keep PTDC on release position and ensure that BP is 5.0 kg/cm² and BC is "0" kg/cm²
- If BC pressure does not come to '0' then release by distributor valve.
- To apply / release auto brakes keep PTDC handle to apply or release as per requirement and clear the block section by 10 KMPH.

CHANGES IN UNDER TRUCK:

BC-1 & BC-2 cocs are not provided in under truck. These cocs are black in color and provided at the bottom of brake manifold in machine room. Normally these coc should be vertical (Open).

2 CHANGES IN PNEUMATIC PANEL IN MACHINE ROOM:

Pneumatic panel is divided into two parts.

- Air Brake Manifold.
- Auxiliary manifold.

1 Air Brake Manifold:

a) Parking Brake Back Up Switch – (PB-BUS):

This is a black colored switch; normally this switch should be in horizontal condition. But in case of PTDC mode or clearing loco as dead, this switch should be kept closed (Vertical) to release the parking brakes.

B) Pneumatic Equalizing Reservoir Cut Off Switch – (PER-COS):

This is a black colored switch; normally this switch should be in horizontal condition. But in case of PTDC mode this switch should be kept vertical.

C) Parking Brake Reservoir Cut Off Switch – (PBR-COS):

This is a black colored switch; normally this switch should be in horizontal condition. Maintenance staff uses this switch.

D) Parking Brake Pneumatic Disable switch- (PB-PDS)

This is a black colored switch; normally this switch should be in horizontal condition. In case of parking brakes malfunctioning maintenance staff uses this switch and kept vertical along with PBR - COS.

E) SIFA-74 (Vigilance exhaust coc):

This is yellow colored coc. Normally this coc should be kept down ward but while clearing loco, as dead this coc should be kept upward.

F) BC- & BC-2 coc:

These are bogie-isolating coc.

G) DV (Distributor valve):

2 Auxiliary Manifold:

Following cocs are provided on this manifold.

- a) **WFL:** Pressure switch for wheel flange lubrication.
- b) **TC1 & TC2:** Pressure switch for traction converter-1 & 2
- c) **KABA KEY:** Loco grounding key.
- d) **FC:** Harmonic filter contactor pressure switch.
- e) **PAN1&2:** Pressure switch for Panto1 & panto2.
- f) **VCB:** Pressure switch for VCB.
- g) **VESA1 & VESA2:** Pressure switch for sanders.
- h) **136:** Pressure coc for Feed Pipe.
- i) **47:** cock for dead loco (normally closed)
- j) **Panto selector switch:** for selection of panto (same as conventional)
(coc position of a to f switch should be horizontal. Coc position of h & i should be vertical.)

ITEMS TO BE NOTED:**1 Energizing of cab:**

Loco should be energized as conventional 3 phase loco, but ensure following:

- i) A-9 handle of driving loco should be at RUN, where as that of non driving cab should be at FS in locked condition.
- ii) Mode switch is at LEAD in driving cab, and at TRAIL in non-driving cab.
- iii) Energize the loco as per normal position.
- iv) For charging BP move A-9 to FS for 10 seconds and then keep it to RUN position. BP will be charged by 3.0 kg/cm²
- v) Ensure that parking braks are released, if not then press BPPB.
- vi) Keep A-9 from RUN to FS. Wait for 10 seconds, then again keep it to RUN and ensure that BP is charged to 5.0 kg/cm² and BC is "0" kg/cm².
- vii) Every time after recharging BP will overcharge to 5.5 kg/cm² at RUN position and then after some time become normal to 5.0 kg/cm²
- viii) For overcharging BP to 5.4 kg/cm² , operate A-9 to REL position.(If necessary)
- ix) For releasing synchronized loco brakes use Bail Ring for quick release or use PVEF for normal release.

2. Procedure Of Cab Changing:

- i) Keep A-9 handle in FS and lock it and remove the key out side.
- ii) Keep the SA-9 in release and rotate MODE switch to trail position.
- iii) Open the DJ, lower the panto and switch off the CE. Remove the BL key and go in another cab.
- iv) In another cab, Unlock A-9 handle and keep it on RUN condition. Operate Mode switch from TRAIL to LEAD.
- v) To charge BP, release parking brake and ensure charging of BP pressure.
- vi) Take these precautions every time while changing the cab.

3. Parking brake – application & release.

Whenever parking brakes are applied by CE or manually, every time penalty auto brakes will be applied along with parking brakes in which BP will drop to 3 kg/cm² and loco brakes up to 2.5 kg/cm² with Priority-1 message on screen.

For recharging BP pressure, first release parking brakes and keep A-9 to FS position for 10 seconds. Again keep A-9 on RUN position and ensure that BP is recharged to 5.0 kg/cm². Acknowledge the fault and work further.

For applying parking brake manually, rotate switch PB-Bus from horizontal to vertical and for releasing vertical to horizontal.

4. Vigilance penalty brakes:

In this loco BP pressure is dropped by 3.0 kg/cm² (in gauge 2.0 kg/ cm²) on application of vigilance parking brakes. Do the following for resetting vigilance penalty brakes:

- i) Keep throttle at "0"
- ii) Wait for at least 2-3 minutes.
- iii) Keep A-9 to FS, press BPVR for acknowledging fault message.
- iv) Keep A-9 at RUN and ensure that BP is charged to 5.0 kg/cm² and loco brakes are released.
- v) Acknowledge the fault by BPFA and proceed further after ensuring pressure.

5 Action to be taken after Emergency Brake Application:

Emergency penalty brakes applied when, emergency push button is pressed or due to over speeding or due to emergency application by A-9 / ALP Emergency valve, in which BP pressure drops to "0". For releasing this penalty brake, keep A-9 to Emergency (EMER) for 10 seconds and again keep to RUN position, BP will charge to 5.0kg/cm² then acknowledge the fault message and work further.

6. Service penalty brakes:

Service penalty brakes apply automatically in following condition in which, BP is dropped to 3.0 kg/cm².

- i) If BC-1 & BC-2 are isolated in locos "LEAD" mode.
- ii) If any one coc of PB-PDS, PB-BUS, PB-R-COS is isolated. If all these switches are in isolated condition and BPPB is pressed then also penalty brakes will apply.

To release service penalty brakes , normalize the above switches, keep A-9 to FS for 10 seconds and then again keep to RUN position and ensure BP to charge at 5.0 kg/cm².

7. Clearing loco as DEAD.

- i) Keep the throttle at "0". Open the DJ, lower the panto, and remove the BL by switching OFF CE.
- ii) Keep the A-9 of both the cab in FS and remove the key after locking it.
- iii) Keep both SA-9 handle at release and keep MODE switch at TRAIL.
- iv) Open coc 47 (Dead loco) and close coc136 (FP) provided on auxiliary manifold.
- v) Keep PAN-1 & 2 (Auxiliary manifold) coc on vertical position.
- vi) Close coc 74 SIFA (Vigilance) provided on pneumatic manifold by keeping upward.
- vii) Switch OFF MCB 112.1 (in SB-2). Drain out the MR & AR.
- viii) Couple the energize loco with dead loco and couple BP/FP pipes and open their angle cocks.
- ix) BC pressure should be '0' and if not then release the distributor valve.
- x) For application and releasing of brakes in dead locomotive rotate PB-BUS (air brake manifold) from horizontal to vertical. Ensure 5 Kg/Cm² pressure in parking brake gauge.

NOTE :-

- a. COC number 70 of BP is not provided in this loco.
- b. Solenoid valve no. 30 is provided in this locomotive.
Before clearing loco as dead ensure that parking brakes are released fully and parking brake gauge is showing 5 Kg/Cm² pressure. Also ensure the same on run.

Chapter-7
DO's and DON'Ts for loco pilots

DO's

1. Acknowledge VCD always within every 60 sec.
2. Do maximum use of regenerative braking, it not only control the train but participate in generating the power.
3. In case of any trouble, as a last step, switch off the CE for 5 minutes.
4. In panto down condition and in CE off condition, to switch on the flasher, use cooling mode.
5. In case of heavy airflow, instead of attending the screen, do the protection of train and adjacent track.
6. In case of emergency use emergency stop push button.
7. While deactivating the CSC , check the position of throttle , it should not be opposite to the force.
8. Use throttle gradually.
9. Before regenerative braking, bunch the load.
10. While working dead loco, ensure conjunction working in dead loco.
11. While working dead loco ensure releasing of parking brakes and pneumatic brakes in dead loco.
12. First note down the fault message and then acknowledge the fault.
13. During failure mode operation, use throttle carefully.
14. Before resetting MCB , first rotate the knob provided on it.
15. Keep the SA-9 handle of rear loco at release.
16. Apply parking brakes when stationary.
17. Instead of continuous operation of sanders, use frequently.

DON'Ts

1. Don't operate BL when loco is in motion.
2. Don't believe on U-meter, ensure the panto physically.
3. Don't press PSA continuously.
4. Don't allow any unauthorized person in rear cab, as some functions are remains active in rear cab.
5. Don't declare the loco FAIL, without switching OFF and ON the control electronics.
6. Don't lower the panto for more than 10 minutes otherwise CE will switch off.
7. Don't forget to acknowledge the fault message.
8. Don't use CSC in undulating area.
9. Don't isolate VCD unnecessarily.
10. Don't switch off CE in running train.
11. Don't smoke in the loco.
12. Don't use quick release position of A-9 frequently and unnecessarily.
13. If MR pressure is less than 6.4 kg/cm², don't operate MPJ.

Chapter – 8
PROTECTION SCHEME

8.1 Protective measures by control electronics:

Initiation of protective measure in dangerous situation are controlled by Control Electronics. MCE monitors a range of values such as voltage, current, temperature, pressure and other signals.

8.1 Catenary voltage out of range

When catenary voltage drop down below 17.0 kv and raise above 30 KV VCB will open automatically.

8.2 Temperature protection

When temp of Transformer exceeds beyond 84 degree C, for more than 10 sec, VCB will trip.

8.3 Primary Over Current Protection (QLM)

Reason for over current.

1. Disturbance in measurement of primary current.
2. Fault in converter.
3. Short circuit in Xmer winding
4. Check machine room for oil flash/smoke/abnormal.
5. Check OCR.78 is in normal.

If any thing is abnormal- fail the loco.

If VCB trips during 'C' mode then check oil level of Xmer and converter and check relay 78. If any thing is abnormal, fail the loco.

8.4 Train Parting:

Airflow measuring valve is provided in loco. Whenever train get parted, or air flow increased and AFM get activated, resulted into glowing of LSAF and sounding of buzzer. Also message of ALARM CHAIN PULLING will appear on screen.

As due to uncoupling / parting, the BP pressure start expelling at very fast rate, resulting into sudden drop in MR pressure which leads to Priority -1 message on screen " Low Pressure Main reservoir"

So, after parting / uncoupling, the driver will get message of low MR pressure which is counter effect.

So, when ever AFI shoot up with sudden drop in BP pressure, your first duty is to act as in case load parting / accident (like switching ON of flasher light, protection of adjacent track, Securing of load / loco, etc.),. After asserting that trailing load is OK, then think about the loco / message.

8.5 Fire Alarm:

In loco fire detention unit is provided in SB2. There are two smoke detector to detect the smoke in machine room.

When one detector detects the smoke –

1. Buzzer will sound
2. Priority-2 message will appear on screen.

When both detectors detect the smoke –

1. Priority-1 message will appear on the screen.- Inspect Machine room
2. Throttle T/E,B/E becomes '0'
3. Buzzer will sound.

Do the necessary arrangement to extinguish the fire by using suitable fire extinguisher provided in Cab1/2 and Machine Room 1/2 (Total 4 Nos.)

Resetting Of Fire Alarm:

1. Press Reset button on fire detection equipment provided in Machine Room (SB-2)
2. Press BPFA.

Action to be taken by Driver

1. Inspect the Machine room and take necessary action. In case of fire on loco, use big fire extinguisher provided in the rack behind asstt. Driver in cab. To operate this fire extinguisher, open the cut out coc and release the gas by rotating adjusting knob, gas will expel and extinguish the fire at appropriate places in machine room behind it. In addition to this two numbers of portable fire extinguishers are provided on the loco which should be used accordingly as per requirement.

2. To reset the FDU, press the white knob provided on it. To acknowledge the fault press BPFA. Resume normal traction.

Note:- In case of defect in FDU, P-2 fault message will appear on the screen. After inspecting the machine room, reset the white knob on the FDU. Acknowledge the fault and keep watch on machine room.

8.6 Alarm Chain Pulling:

When airflow increases without initiated by driver or CE i.e. in case of ACP/Gds brake applied/leakage in train/HPD etc. Following indication appears.

1. Air Flow Indicator needle will deviate.
2. LSAF will glow.
3. Buzzer will sound.
4. BPFA will illuminate with P-2 message.
5. Auto flasher will start.

ACP Indication:

1. Put right the ACP/leakage.
2. Buzzer will sound continuously until the leakage/ACP is arrested so to stop sounding,. Press BPFA. If ACP/leakage is not arrested buzzer will start again.
3. When ACP leakage is put right, all indications will disappear, but for BPFA indication press it once.

**Chapter – 9
PREPARATION**

CAB OVER VIEW

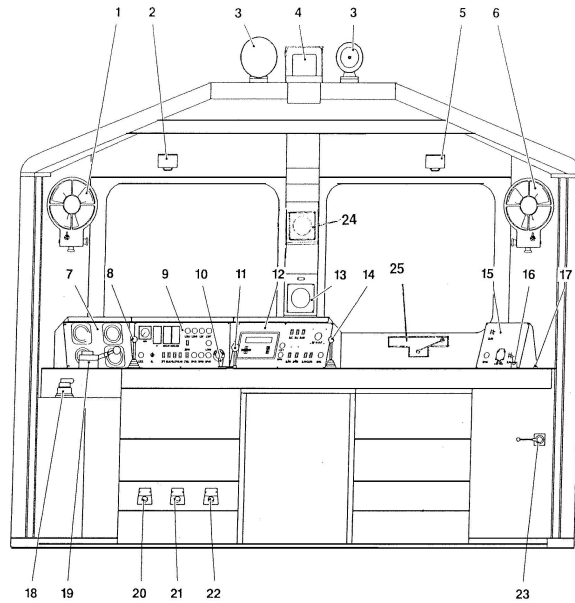

CAB OVER VIEW

- | | |
|--|---|
| 1 Crew fan | 14 Control lever for horn |
| 2 Lamp driver's desk illumination | 15 Panel D |
| 3 Pneumatic horn | 16 Operation of window wipers/washers |
| 4 Emergency flash light | 17 Rotary switch cab heater/fan device |
| 5 Lamp assttand driver's desk illumination | 18 Brake handle direct loco brake |
| 6 Crew fan | 19 Brake handle automatic train brake |
| 7 Panel B | 20 Foot switch "SANDING" |
| 8 Control lever for horn | 21 Foot switch "PVEF" for release of loco brake |
| 9 Panel A | 22 Foot switch "VIGILANCE" |
| 10 Reverser | 23 Emergency brake cock |
| 11 TE/BE Throttle | 24 Parking Brake (PB) gauge |
| 12 Panel C | 25 Wiper motor |
| 13 MEMOTEL | |

PANEL- A

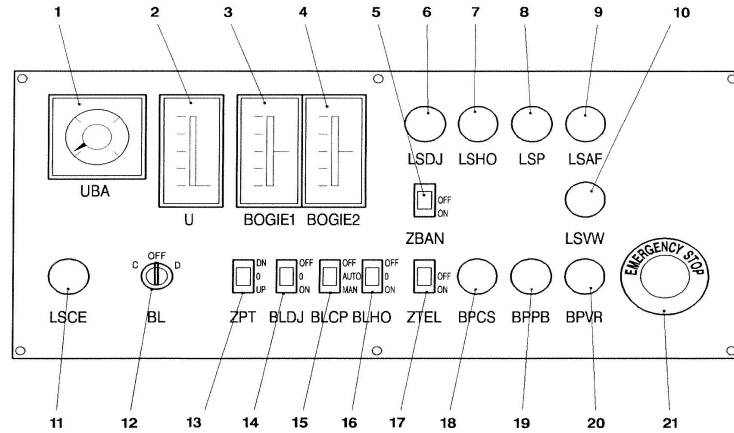

- 1 UBA Voltmeter Battery voltage
- 2 U Voltmeter Catenary voltage
- 3 BOGIE 1 TE/BE meter - Traction / braking effort, bogie 1
- 4 BOGIE 2 TE/BE meter - Traction / braking effort, bogie 2
- 5 ZBAN Spring loaded switch – Banking operation “ON” / “OFF”
- 6 LSDJ Indication lamp, red - Main circuit breaker “OFF”
- 7 LSHO Indication lamp, yellow - Hotel load “ON” (Inactive on WAG—9)
- 8 LSP Indication lamp, yellow - Wheel slipping
- 9 LSAF Indication lamp, red - Train parting
- 10 LSVW Indication lamp, yellow - Vigilance warning
- 11 LSCE Lamp, amber - Over temperature CEL
- 12 BL Key switch - Activation of Driver’s cab
- 13 ZPT Spring—loaded switch - Raise / Lower Pantograph
- 14 BLDJ Spring—loaded switch –
Main circuit breaker “ON” / “OFF”
- 15 BLCP Spring—loaded switch - Main compressors
AUTO mode “ON” / “OFF”
- 16 BLHO Spring—loaded switch - hotel load “ON” | “OFF”
(Inactive on WAG—9)
- 17 ZTEL Switch - Max. Traction limitation
- 18 BPCS Illuminated pushbutton – green-constant Speed control
- 19 BPPB Illuminated push—button- red - Parking brake
- 20 BPVR Push—button, yellow Resetting vigilance
- 21 Emergency Stop - button – red - Emergency stop

GAUGES – PANEL-B

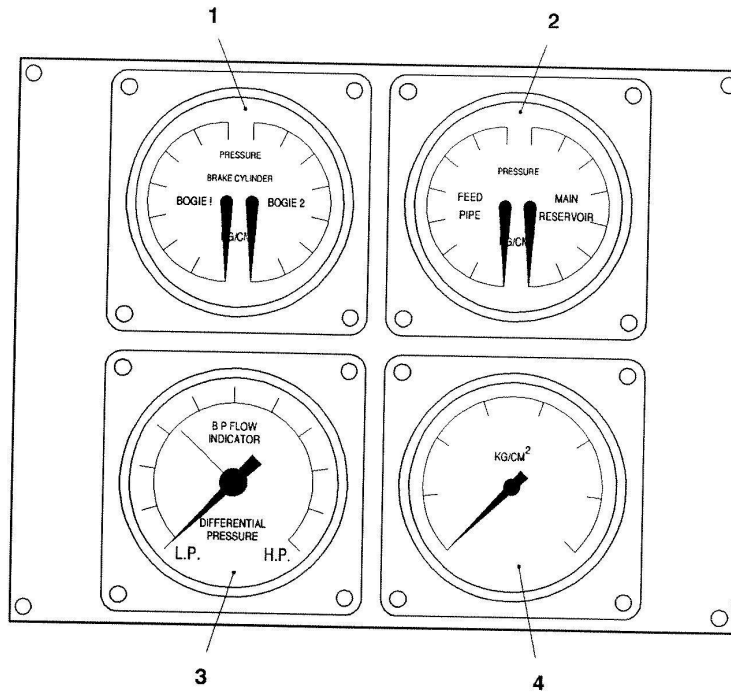

- 1 Pressure Brake Cylinder Bogie 1+2
- 2 Pressure Brake Feed Pipe/Main Reservoir
- 3 Air Flow Meter
- 4 Pressure Brake Pipe

PANEL-C

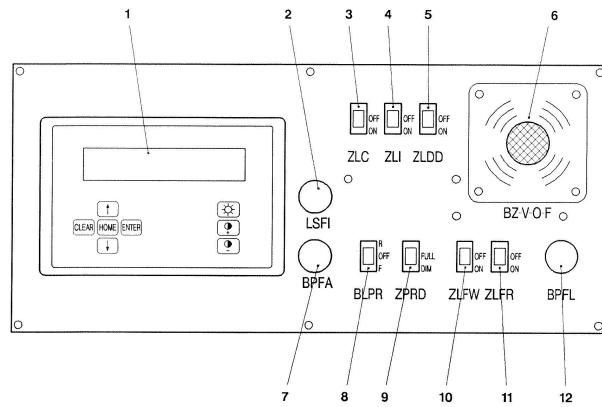

- 1 Screen Display of messages diagnosis
- 2 LSFI Indication lamp, red - Fault message, priority 1
- 3 ZLC Switch - Driver's cab lighting
- 4 ZLI Switch - Instrument lighting
- 5 ZLDD Switch - Driver's desk illumination
- 6 B-Z-V-O-F- Buzzer - Warning signal, 3 frequencies
- 7 BPFA Illuminated push - button, yellow - Acknowledgement all fault messages
- 8 BLPR Switch - Head Light, Bright
- 9 ZPRD Switch - Headlights, Dim
- 10 ZLFW Switch - Marker lights, white
- 11 ZLFR Switch - Marker lights, red
- 12 BPFL Illuminated push - button, yellow - Emergency flash light

PANEL-D

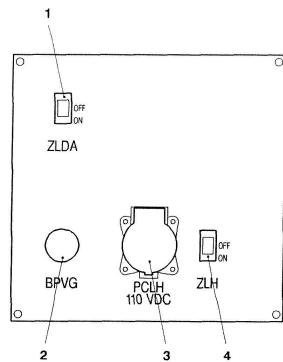

- 1. Asstt Driver Desk Lamp
- 2. Vigilance Ack push button
- 3. 110V socket
- 4. 110 V socket ON/OFF button

MACHINE ROOM LAYOUT

WAG-9/WAP-7

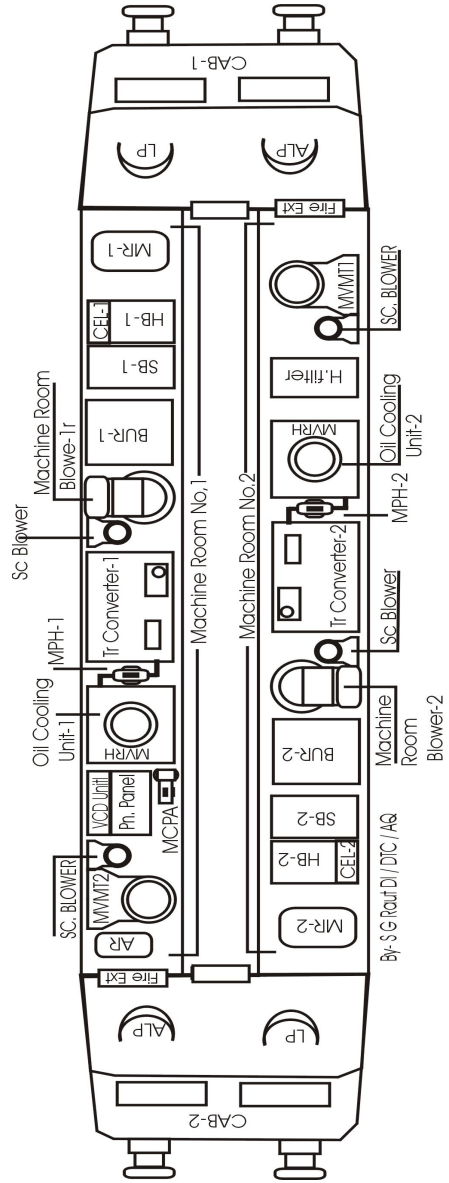

WAP-5

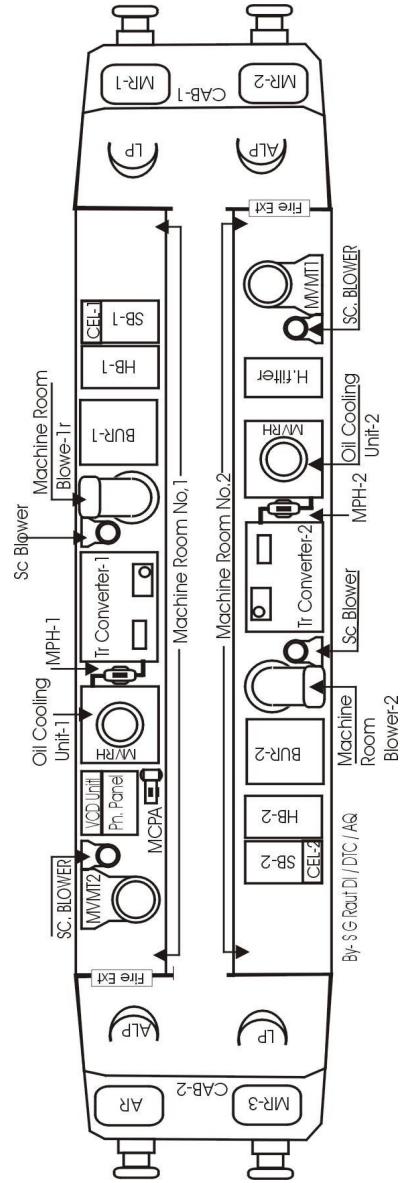

PNEUMATIC PANEL

- COC-74 = Emergency exhaust coc.(Open)
- COC-70 = BP charging coc. (Open)
- COC-136 = FP charging coc.(Open)
- COC-47 = Dead loco (AR charging) coc.(close)
- PAN-1 cock = Panto -1 pneumatic control coc. (Open)
- PAN-2 cock = Panto -2 pneumatic control coc.(Open)
- VCB cock = VCB (DJ) pneumatic coc.(open)
- Sand-1&2 cock = Sander pneumatic control cock.(Open)
- Solenoid -30 = Parking brake solenoid valve.
- IG-38 = Pneumatic control key.(Open)
- E-70 = BP charging valve (like Add C-2 relay valve).
- C3W = Distributor valve.

COC	74	70	136	47
LIVE -SU	Open Horizontal	Open Horizontal	Open Vertical	Close Horizontal
DEAD (Towed)	Close Vertical	Close Vertical	Close Horizontal	Open Vertical
As Banker	Open Horizontal	Close Vertical	Close Horizontal	Close Horizontal

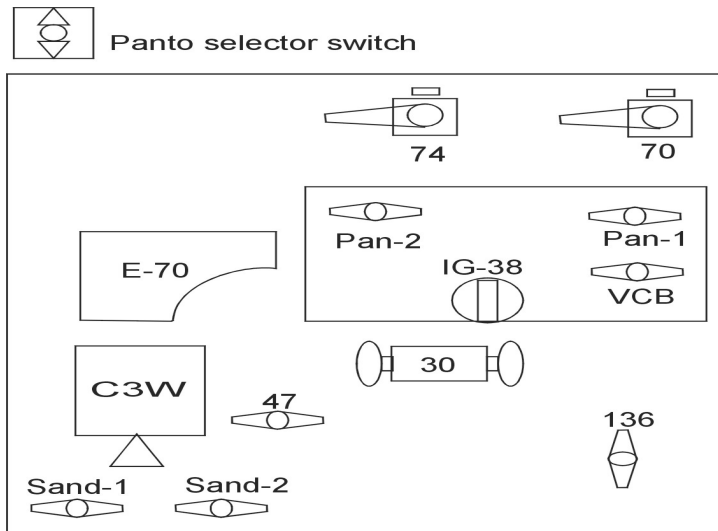

(Refer Photograph of Pneumatic panel pasted at last)

Circuit breakers provided in HB-1

Three phase 415 Volt Aux. circuit breaker

62.1/1 **63.1/1** **47.1/1** **53.1/1** **55.1/1** **59.1/1**

Single phase 415 /110 Volt Aux.circuit breaker

54.1/1 **56.1/1** **69.61** **69.62** **69.71**

Three phase 415 Volt Aux. Circuit breaker

1. 62.1/1 Circuit breaker oil pump transformer
2. 63.1/1 Circuit breaker oil pump converter
3. 47.1/1 Circuit breaker, main compressor
4. 53.1/1 Circuit breaker, traction motor blower
5. 55.1/1 Circuit breaker, scavenge blower for traction motor blower and oil cooling
6. 59.1/1 Circuit breaker, oil cooling unit for transformer/ converter

Single phase 415 /110 Volt Aux.circuit breaker

1. 54.1/1 Circuit breaker, machine room blower
2. 56.1/1 Circuit breaker, scavenge blower for machine room blower
3. 69.61 Circuit breaker, cab ventilation
4. 69.62 Circuit breaker, cab heater
5. 69.71 Circuit breaker, crew fan

Circuit breakers provided in HB-2

Three phase 415 Volt Aux. circuit breaker

62.1/2 **63.1/2** **47.1/2** **53.1/2** **55.1/2** **59.1/2**

Single phase 415 /110 Volt Aux.circuit breaker

54.1/2 **56.1/2**

Three phase 415 Volt Aux. circuit breaker

1. 62.1/2 Circuit breaker oil pump transformer
2. 63.1/2 Circuit breaker oil pump converter
3. 47.1/2 Circuit breaker, main compressor
4. 53.1/2 Circuit breaker, traction motor blower
5. 55.1/2 Circuit breaker, scavenge blower f or traction motor blower and oil cooling
6. 59.1/2 Circuit breaker, oil cooling unit, transformer/ converter

Single phase 415 /110 Volt Aux.circuit breaker

1. 54.1/2 Circuit breaker, machine room blower
2. 56.1/2 Circuit breaker, scavenge blower for machine room blower

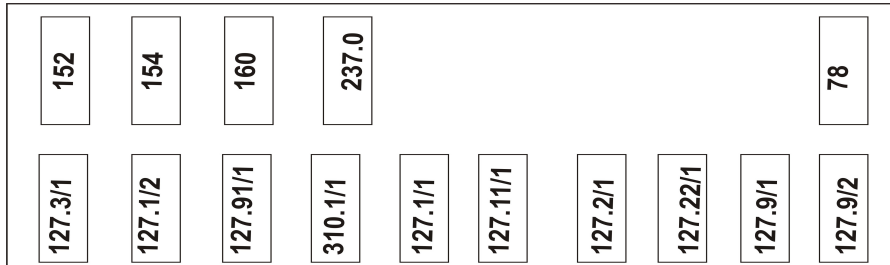

Mini Circuit breakers provided in SB-1

- 1 127.3/1 Circuit breaker Driver's cab
- 2 127.12 Circuit breaker Pantograph ,VCB Control
- 3 127.9/1/1 Circuit breaker Power supply 24V/48V
- 4 310.1/1 Circuit breaker Lighting front
- 5 127.1/1 Circuit breaker Electronics traction converter
- 6 127.1 1/1 Circuit breaker Power supply Gate Units
- 7 127.2/1 Circuit breaker Monitoring
- 8 127.22/1 Circuit breaker Electronics, auxiliary converter
- 9 127.9/1 Circuit breaker Central electronics
- 10 127.9/2 Circuit breaker Central electronics

Rotating Switches

- 11 152 Rotary switch Failure mode operation
- 12 154 Rotary switch Bogie cut-out
- 13 160 Rotary switch Configuration
- 14 2371 Rotary switch Vigilance device cut-off

Relay

- 15 78 Relay Over Current Relay

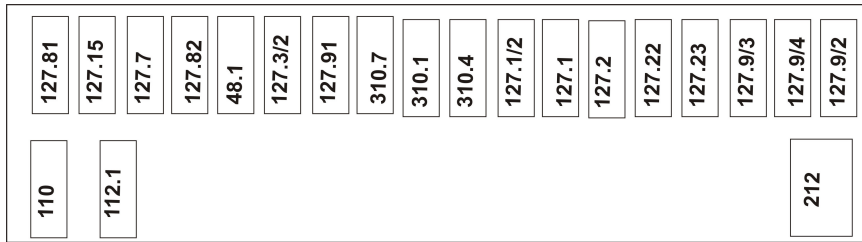

Mini Circuit breakers provided in SB-2

- | | | |
|----|-----------|---|
| 1 | 127.81 | Circuit breaker Commissioning 1 |
| 2 | 127.15 | Circuit breaker Vigilance control |
| 3 | 127.7 | Circuit breaker Pneumatic panel |
| 4 | 127.82 | Circuit breaker Commissioning 2 |
| 5 | 48.1 | Circuit breaker Auxiliary compressor |
| 6 | 127.3/2 | Circuit breaker Driver's cab |
| 7 | 127.91/2 | Circuit breaker Power supply 24V/48 V |
| 8 | 31 0.7/1 | Circuit breaker Marker lights |
| 9 | 310.1/2 | Circuit breaker Lighting front |
| 10 | 310.4 | Circuit breaker Lighting machine room |
| 11 | 127.1/2 | Circuit breaker Electronics traction converter |
| 12 | 127.1 1/2 | Circuit breaker Power supply Gate Units |
| 13 | 127.2/2 | Circuit breaker Monitoring |
| 14 | 127.22/2 | Circuit breaker Electronics auxiliary converter |
| 15 | 127.22/3 | Circuit breaker Electronics auxiliary converter |
| 16 | 127.9/3 | Circuit breaker Central electronics |
| 17 | 127.9/4 | Circuit breaker Central electronics |
| 18 | 127.92 | Circuit breaker MEMOTEL speedometer |
| 19 | 110 | Circuit breaker out put battery charger |
| 20 | 112.1 | Circuit breaker control circuit locomotive |
| 21 | 212 | Fire detection equipment |

PROGRAM SWITCHES

152 Rotary switch Failure mode operation

Position

- 0 - Normal Position Fine control throughout the range
- 1 - Failure mode Fine control in steps through aux. contacts

When throttle is not responding then Driver can keep this switch from 0 to 1 and now same throttle will respond, called failure mode operation.

154 Rotary switch Bogie cut-out

Position

- NORM** : Traction converter-1 & 2 (All TM's) in service
- I** : Traction converter-1 (TM 1-2-3 WAG-9/WAP-7) (TM1-2 WAP-5) isolated
- II** : Traction converter-2 (TM 4-5-6 WAG-9/WAP-7) (TM 3-4 WAP-5) isolated
- I+II** : Traction converter-1 & 2 (TM 1-2-3 & 4-5-6 WAG-9/WAP-7) (TM1-2 & 3-4 WAP-5) isolated

160 Rotary switch Configuration

Position

- 1 : Normal Normal mode
- 0 : Shunting (Max Speed 15 KMPH) mode

237.1 Rotary switch Vigilance device cut-off

Position

- 1 : Normal VCD is in service
- 0 : VCD is isolated

Chapter – 9**PREPARATION****9.1 Loco Preparation And Inspection:**

Before commissioning Journey, perform an inspection check of the locomotive and through the machine room. In particular, check the following items:

1. In front Of Cab:

1. Ensure that loco is standing on the rail and under the OHE
2. Ensure that both side MRE, BCE BP , FP hoses are connected properly and their angle cocs are as per requirement. Also ensure that hoses are not hanging.
3. Ensure that rail guard, cattle guard, has not any damages
4. Ensure that CBC having no abnormalities and locking pin is available and provided with operating handle.
5. Ensure that UIC connector sockets are covered.
6. Ensure that Flasher light, marker lights, headlights are glowing properly and their glasses are clean.
7. Ensure that both look out glasses are clean and wipers are wiping properly.

2. Below Machine Room No. 1(Cab-1 To Cab-2)

1. Ensure that all sand boxes are filled with dry fine sand and sanders are working properly.
2. Ensure that additional angle coc of MRE & BCE are opened.
3. Ensure that Air dryer unit is in service that (D-in open, D- out open & D-off closed)
4. Ensure that all suspension dampers; helical springs having no abnormalities like, crack etc.
5. Guide rod is fitted properly and its bolts are tightened.
6. All brake rigging; brake block, brake shoe, sleeve rod, assembly hanger arrangement are OK.
7. Wheels are not skidded.
8. Return current bush are connected properly.
9. Parking brakes cylinders are provided with manual releaser hook.
10. Traction link is fitted properly and their all 6+6 bolts are tightened.
11. Oil level in CP is above min mark; also ensure that CP foundation bolts are tightened.
12. Bogie brake -1 coc is in open condition.
13. Battery box cover is locked.
14. Safety chain is intact.
15. BP and FP additional coc are in open condition.

3. Below Machine Room No. 2(Cab-2 To Cab-1)

1. Ensure that all sand boxes are filled with dry fine sand and sanders are working properly.

2. Ensure that additional angle coc of MRE & BCE are opened.
3. Ensure the all suspension dampers, helical springs having no abnormalities like, crack etc.
4. Guide rod are fitted properly and its bolts are tightened.
5. All brake rigging; brake block, brake shoe, sleeve rod, assembly hanger arrangement are OK.
6. Wheels are no skidded.
7. Return current bush are connected properly.
8. Parking brakes cylinders are provided with manual releaser hook.
9. Traction link is fitted properly and their all 6+6 bolts are tightened.
10. Oil level in CP is above min mark; also ensure that CP foundation bolts are tightened.
11. Bogie brake -2 coc is in open condition.
12. Battery box cover is locked.
13. Safety chain are intact.
14. BP and FP additional coc are in open condition..

4 In Cab

1. Cab and look out glasses are clean.
2. All switches are normal, ZBAN-OFF, BLCP-AUTO
3. Emergency exhaust cock are normal.
4. Water is filled up in windshield washer unit.
5. Spare hoses, wooden wedges are provided in side locker.
6. Fixed and handy both fire extinguisher are in good condition and filled with gas.
8. Ensure that emergency push button is released.

5. In Machine Room

1. Control and power Circuit breakers in cubicle SB-1 / SB-2 , HB-1 and HB-2 are normal
2. Switches provided in SB-1 are at normal position.
3. Oil level of conv-1/2 and transformer-1/2 are above min mark.
4. All fittings and connections are normal.
5. Outer cover of any power equipment is not opened.

6. Pneumatic Panel

1. Panto selector switch is at "auto" position.
2. COC 70,74,136 are in open condition and COC 47 is in close position.
3. COC of panto 1, panto 2, VCB and sandars are in open condition.
4. Distributor valve is in service.
5. IG 38 Key is inserted and kept 'ON'.
6. CPA drain cock is in close condition.
7. Parking brake apply/release plungers are not in locked condition.

Chapter – 10**ON LINE MOVEMENT
(Different operations)****10.1 How To Energise The Loco:**

1. Check the machine room and cubicle HB1/2,SB1/2 and pneumatic panel and ensure that all Circuit breakers, rotating switches and cock at Pn. Panel are at Normal position and ensure that key 'IG-38' is provided on pneumatic panel. Also ensure that panto selector switch is at normal position.
2. Lit compartment light , it ensures closing of main circuitry breaker 112 of battery.
3. Put battery additional circuit breaker No.112.1 to 'ON' position in cubicle SB-2. Also ensure that CHBA circuit breaker no. 110 (SB-2) is at ON position.
4. Go in operating cab.
5. Insert A-9 handles at 'Neutral' position and keep it in 'RUN' position by lifting lock.
6. Insert 'BL' key at 'OFF' position and turn it to 'D' position
 - a. Light of screen (panel-C) and Memotel will get ON.
 - b. MCPA will start (if pressure is less).
 - c. UBA will deviate to 110 volts.
 - d. LSDJ will glow.

All above indications indicates that Control Electronics is get 'ON'.
7. The message "Loco is in configuration, please wait" will appear on the screen and self testing is done for 10 seconds.
8. During testing, all pilot lamps will glow and extinguish, Bogies-1 & 2 meter will deviate both in TE/BE mode and come to -0
9. After testing FLG No. 504, will be displayed on the screen, Now press 'ZPT' in 'UP' mode for raising of pantograph and confirm the touching of panto with contact wire by seeing physically also U-meter will deviate and indicate the value of OHE voltage.
10. No.550 will display on the screen- now press BLDJ for closing VCB and check 'LSDJ' is extinguished.
Now DJ will close, loco will energize and the all auxiliary will get start automatically.
11. Ensure that BLCP is at AUTO position.
12. No.570 will appear on the screen.
13. After MR pressure build up to 6.4 Kg/Cm², set Reverser to F/R as per requirement. (FLG 590 will show on the screen.)

Note:- If the reverser is set without confirming the MR pressure i.e above 6.4 kg / cm² , then P-1 message will be there on screen- indicating wrong operation.

14. Apply loco brakes
Now release the parking brakes
Ensure BP pressure to 5 KG/m²
Ensure AFI is at Zero.
15. Now operate throttle in TE direction.
16. TE /BE meter will deviate in TE side indicating that traction is available.
No. "596" will appear on the screen.
17. Check the loco brake power. Release loco brake.
18. Now you can move the train / loco.

Note:

Priority -1 message will appear on the screen if: -

1. If Reverser is put on position F or R before when MR pressure is below 6.4 kg/cm²
2. If throttle is operated without releasing parking brakes.
3. If throttle is operated without recharging BP to 5 kg / cm².

Information message will appear on the screen if :-

1. If throttle is operated before node information No. 590.

10.2 Operation Of BL Key

BL key is operated for following mode:

1. DRIVING MODE: (Off - D)
2. SELF HOLD MODE. (D - Off)
3. Switching OFF control electronics: (D - Off - C - Off)
4. COOLING MODE: (D - Off - C - Off - C)

10.3 Driving Mode:

This mode is used to drive the loco. To achieve this mode driver has to:

- 1) Insert BL key in 'OFF' position.
- 2) Turn it clockwise from 'OFF' to 'D'
- 3) By doing this, following indications will confirm the driving mode:
 - a) LSDJ will glow
 - b) UBA will show battery voltage.
 - c) Display screen will activate.
 - d) Memotel screen will activate.
 Control electronics will get ON.

10.4 Self Hold Mode:

- 1) Open DJ , lower the pantograph
- 2) Rotate 'BL-key' from 'D' to 'OFF': Now control electronics will remain 'ON' for 10 minutes and then it will become 'OFF' automatically. This mode is used while changing the cab.

10.5 Switching Off - Control Electronics:

Driver has to switch off control electronics in many cases like;

- a) Making the loco dead.
- b) During troubleshooting.
- c) For taking the isolated sub system in service.
- d) Before e resetting circuit breaker or before rotating any switch.

To switch off the control electronics do the following:

- 1) Stop the train
- 2) Open the DJ and lower the pantograph.
- 3) Operate BL-key from 'D' to 'Off' (wait for 2 sec.)
- 4) Operate BL-key from 'Off' to 'C' and wait until display screen, LSDJ, and UBA goes off.
- 5) It indicates that CE is get 'OFF' and now rotate it from 'C' to 'OFF'

Note :

- 1) C.E. get automatically 'off' after 10 minutes if BL-key is rotate from 'D' to 'OFF' (as explained in self hold mode.)
- 2) C.E. will get 'off' automatically after 10 minutes in driving mode also, if panto is remain lower for more than 10 minutes.
- 3) If the key switch is moved from Pos. "D" to Pos. "Off" without opening the VCB, and the panto graph lowering, this will initiates an automatic shutdown on loco.

10.6 Cooling Mode:

Whenever temperature of control electronics is increases above 70⁰ then lamp LSCE glows on Pannel 'A' and throttle will not respond.

Control/Coast the train to stop at suitable place like starter etc.

1. Try to stop the train at suitable place.
2. Inform TLC/SCOR regarding cooling.
3. Keep the throttle on '0'.
4. Keep SA9- at applied condition and A-9 to emergency.
5. Open VCB and lower the pantograph.
6. Switch off CE as per procedure.

7. Put 'BL' key from 'C' to OFF.
8. Again put 'BL key' from 'Off' to 'C' and ensure that UBA shows battery voltage and LSDJ glows, Screen is Off - no node information. (Note CE is OFF)
9. Now raise the panto, close the VCB- LSDJ will extinguish and loco will energize in cooling mode.
10. Machine room blowers & scavange blowers will start automatically to cool the machine Room. Ensure working of machine room blowers.
11. When the machine room temperature goes below 70°C then LSCE will extinguish.
12. Now Open the VCB, lower the pantograph.
13. Put BL from 'C' to 'Off' and 'off' to 'D' and energize loco & resume traction.

10.7 Operation Of Reverser :

Reverser has following 3 positions.

- Position 'F' = Forward
- Position 'O' = Neutral
- Position 'R' = Reverse

Throttle and reverser are interlocked mechanically.

10.8 Driving:

1. After creating MR pressure above 6.4 kg/cm² and node information no. 570.
2. Move the reverser into desired position.
3. Release the parking brake if applied
4. Put A9 to 'RUN' position & ensure BP 5 KG/cm²
5. Check AFI is not deviating.
6. Set the TE/BE throttle to desire position.
7. Put SA9 handle to 'Release' position.
8. In order to increase adhesion and to avoid wheel slipping use sanders.
9. Bogies 1 & 2 meters will show in TE side and loco started

10.9 Braking:

1. Set the TE/BE throttle to - '0' or move towards braking side as per requirement..
2. Move A9 from 'RUN' to 'Initial Application'. If more brake force is required move the A9 handle to desire position between 'Initial Application' and ' Full Service' & Vice versa gradually.
3. Reg. Braking is possible up to 0 KMPH.
4. When train stops, apply SA9.
5. Max. Brake force is 260 KN in WAG-9/WAP-7 & 160 KN in WAP-5.

Note :- Train brakes can be applied with Regenerating brakes but Loco brake can not be applied simultaneously with Regenerating brkes.

10.10 Operation Of Throttle:

TE/BE Throttle

The TE/BE throttle controls traction and the electric braking effort of the locomotive with an angle transmitter and auxiliary contacts.

The TE/BE throttle has the following three end positions:

For Traction

Position 1/3	33% tractive effort
Position 2/3	67% tractive effort
Position TE max	100% tractive effort

Position "0" no tractive / no braking effort

For Regenerative Braking effort

Position 1/3	33% braking effort
Position 2/3	67% braking effort
Position TE max	100% braking effort

NOTE:

If TE doesn't increase beyond 300 KN in WAG-9/WAP-7 & 150KN in WAP-5 then Driver should check ZTEL switch on 'A' Panel whether it is 'ON' or 'OFF', ZTEL should be kept 'OFF'.

The % tractive/braking effort is indicated on the two-tractive/braking meters on panel A.

10.11 Failure Mode Operation

This mode allows the locomotive to operate even if the angle transmitter of the TE/BE throttle has failed.

In this mode, driving and electrical braking are controlled by the auxiliary contacts on the TE/BE throttle.

Driving in failure mode

Driving in failure mode becomes necessary if the difference between auxiliary contacts and the absolute value of the angle transmitter is greater than 25% of the full range because of a defective master controller.

The following steps are initiated with a time delay of 2 sec:

1. Traction is set to 0 by the MCE.
2. A priority 2-fault message is displayed.

3. The driver must now move the rotary switch “152-Failure Mode Operation” in the machine room (SB1) into position ‘1’. This deactivates the angle transmitter.
 4. The driver must move the TE/BE throttle into position “0”.
 5. The driver must acknowledge the fault message.
 6. The driver can now select a new TE/BE throttle value carefully.
- Position ‘0’ - Fine control though out the range by angle transmitter.
 Position ‘1’ - fine control in steps though auxiliary contacts.

10.12 Loco Brake Testing:

- 1) Apply loco brakes by SA-9
- 2) Ensure that brake cylinders registered 3.5 kg / cm² pressure.
- 3) Release parking brakes and release A-9.
- 4) Operate MPJ to forward.
- 5) Move throttle in traction and give 45 % tractive effort.
- 6) Loco should not be moved.

Note :- Presently there is no procedure for loco brake testing approved by RDSO. Same to be confirmed by RDSO or CLW.

10.13 How To Change The Cab :

Single Unit

1. Open ‘DJ’ by pressing BLDJ at ‘OFF’
2. Lower the panto by pressing ZPT at ‘DN’
3. Operate BL key from ‘D’ to ‘off’ and remove it. (CE will remain ON for 10”)
4. Apply loco brakes by SA-9
5. Set automatic brake controller to position ‘Neutral’ and then remove handle
6. Release direct brake handle.
7. Go in another cab and energize it in “Normal” way.

Note:

- * If BL key is taken ‘OFF’ without opening DJ and lowering panto , loco will be shutdown as emergency shutdown will initiate on loco.
- * During normal driving if BL key is kept ‘OFF’ ,emergency brakes will get applied as emergency shutdown will initiate on loco.
- * After moving the key switch ‘BL’ to position ‘O’, the MCE remains active for 10 minutes. The change of driver’s cab should take place during this time, If the MCE has to be restarted, it takes longer to set up the locomotive because Peripheral tests have to be carried out.

Multiple unit

1. Move key switch 'BL' on master locomotive into position 'Off' and remove the key.
2. Set automatic brake controller to position 'Neutral'
3. Release direct brake
4. Set the brake pipe cock 70 to the 'Close' Position
5. Change the loco and set the brake pipe cock 70 to the 'Open' position on this previous slave loco.
6. Insert key in driver's cab of previous slave loco.
7. Move key switch "BL" into position "D"

Note:

The change of driver's cab has to take place within this 10 minutes period otherwise the MCE has to be restarted.

10.14 Banking Mode

When it is required to use loco as a banker i.e use of TE / BE without charging BP, at that time loco should be operate in banking mode.

Procedure:

- 1) Trip the VCB and Set switch "ZBAN" "to position "ON" (Panel A).
- 2) Close coc 70 & 136 provided on Pn panel.
- 3) Set up the loco in the normal manner.
- 4) BP pressure will be drop to 0 , but when coupled with master loco, its BP will rush into BP pipe of this loco which will seen in the gauge.

Note: During the Set Up, the train driver receives a priority 2 messages that banking mode is active.

10.15 Constant Speed Controller:

This system enables the train to maintain a constant speed automatically and can be activated at any speed above 5 KMPH by pressing illuminated push button 'BPCS'.

The control electronics and GTO controls the constant speed by giving tractive or braking effort to the TM as per requirement irrespective of position of throttle (ATDC-Angle transmission driver Controller) i.e. TE/BE .

The actions of CSC are cancelled in following conditions.

1. Moving of throttle.
2. Pressing 'BPCS' while CSC is active, lamp will extinguished.
3. Drop in 'BP' by 0.25 Kg/Cm² and above.
4. BC pressure more that 0.6 kg/Cm²

CSC is activated only when

1. Speed is more than 5 KMPH
2. Throttle in either TE or BE side.
3. Train Br. and loco Br. are not applied
4. BPCS is pressed once, lamp will lit.

Some thing Important:

- 1) To minimize oscillation, the CSC should be set during a slow acceleration phase.
- 2) CSC will maintain the speed only up to max TE / BE. Speed may vary if required TE / BE is more than loco capacity. So, in an undulating area the speed may vary +/- 10 kmph to preset value.
So in such areas BPCS should be pressed at the speed with margin of 10 KMPH.
Also in some areas where special driving technique is required, CSC may stall the train. So, in such areas, instead of using CSC, L.P. should use his best driving technique by operation of throttle.
- 3) Also if CSC is used in very frequent up / down grade region, the loco will trigger for TE to BE and BE to TE very frequently with heavy amplitude, which is not good as far as driving technique is conserved.
- 4) While canceling CSC ensure that middle position of TE/BE meter and throttle are not just opposite. If so, first bring the throttle as per middle.

10.16 Emergency Stop Push Button

One red colored and arrowed push button is provided on panel 'A' at such a place that driver as well as Asst. driver can operate it. In normal condition it remain projected out. In case of an emergency if drivers/Asst. push this button, button go inside and remain pressed and following actions initiated.

1. VCB get opened. 2. TE/BE comes to '0'
3. Panto lowered 4. BP drops to 0 Kg/cm²- Train/Loco brakes applied.
5. LSFI/BPFA glow with message.
" Emergency shutdown on the loco" on screen and train will stop with emergency brakes.

Resetting:

- 1) Bring TE/BE throttle to '0'.
- 2) Press "emergency stop push button" slightly and rotate it clockwise as per arrow indication on it, the button will comes out from pressed condition.
- 3) Press BPFA and acknowledge the fault and node information will appear.
- 4) Flasher light will lit.
- 5) Energise the loco and work the train as per procedure given.

10.17 Automatic Vigilance Control System:

VCD is meant for checking and keeping the driver alert. It is a safety device. A foot switch of VCD is provided below driver's desk in each cab, also press button 'BPVG' is provided on drivers' desk on Asst. side.

Driver/Asst. driver is expected to activate VCD within every 60 seconds interval by one of the following way.

1. Press VCD "Foot switch" OR
2. Press BPVG (Green) OR
3. Operate throttle in TE/BE in different of more than 3% OR
4. Operate 'Sanders'.

If one of the above exercises is done, the driver is considered alert and the 60 seconds cycle get reset.

If none of the above activities are done once within 60 seconds, then buzzer will sound and 'LSVW' will glow for next 8 seconds.

Within these 8 second acknowledge the VCD by pressing 'vigilance footswitch' or 'BPVG', if not acknowledged, VCD will apply penalty with emergency braking (2.5 – 3.0 Kg/cm²). TE/BE will become '0' & BP pressure will drop 2.5 to 3.0 kg/cm²

Note:

For VCD, the speed of train should be more than 1.5 KMPH.

10.17.1 Dead Mans Mode:

If VCD 'Foot switch' lies remain pressed for more than 60 second, then the system will go automatically in "Dead Mans" mode, & buzzer will sound, if not released with next 8 second, VCD penalty will be applied with emergency braking. The BP will drop 2.5 to 3.0 kg/cm²

10.17.2 Resetting Of VCD Penalty Brakes:

1. Bring throttle to '0'
2. Wait for 160 seconds in WAG-9/WAP-7 and 120 seconds in WAP-5 without switching ON/OFF of the electronics
3. Press "BP-VR" to reset VCD, LSVW will extinguished and buzzer will stop.
4. Press and release VCD "Foot switch".
5. Press 'BPFA' for acknowledging fault message.
6. MR/BP pressure would come back to normal
7. Resume 'Normal' traction.

10.17.3 Isolation Of VCD :

If driver is acknowledging VCD correctly as per procedure, but till VCD penalty is applying, in that case it is assumed that VCD is malfunctioning. In such cases stop the train, take safety measures. VCD can be bypassed by keeping switch no. 237.1 (SB-1) on '0' position. Remark should be given in log book, TLC is to be informed and proceed carefully.

10.18 PASSING NEUTRAL SECTION (SU)

Before approaching neutral section:

1. Ensure that MR pressure is between 8.5 to 10 kg/cm²
2. Bring TE / BE throttle to '0' gradually before 250M board.
3. At DJ open board, open DJ by BLDJ, LSDJ will glow, Aux. sound will stop, but U meter will show OHE supply.
4. At actual neutral section location, OHE meter will comes down to "0" and will shoot up when neutral section over.
5. In PTFE type neutral section, at higher speed, needle will just fluctuate.
6. At DJ close board close VCB (DJ), and resume normal traction.

In case MU operation

- The command from the master locomotive to switch the main circuit breaker "ON" , "OFF" also controls the main circuit breaker on the slave loco.
- The VCB of the slave loco is switched on after a delay of 0.5 seconds following the switch on of the master loco. When switching off, there is no delay.
- While passing neutral section follow the procedure mentioned for SU, but DJ should be closed after passing one mast after DJ close board.

**Chapter-11
FAULTS**

11.1 Display Screen

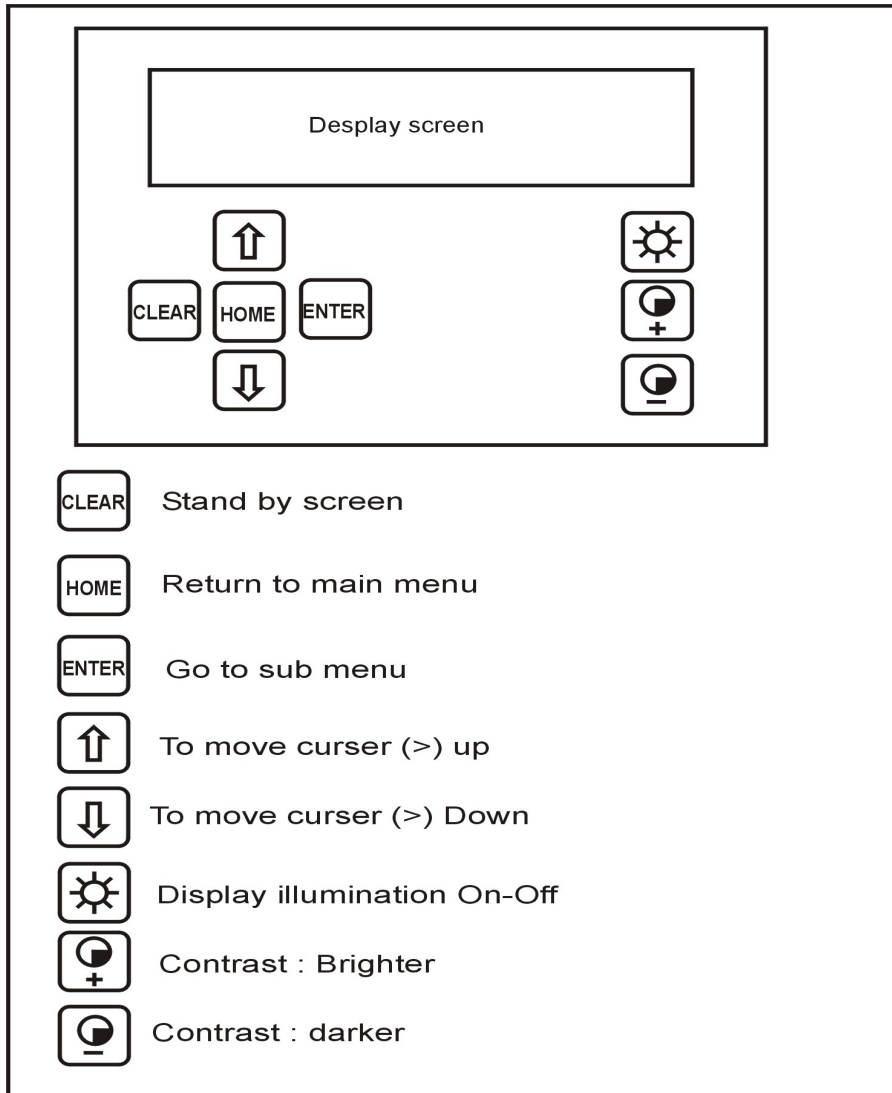

11.2 Screen Structure

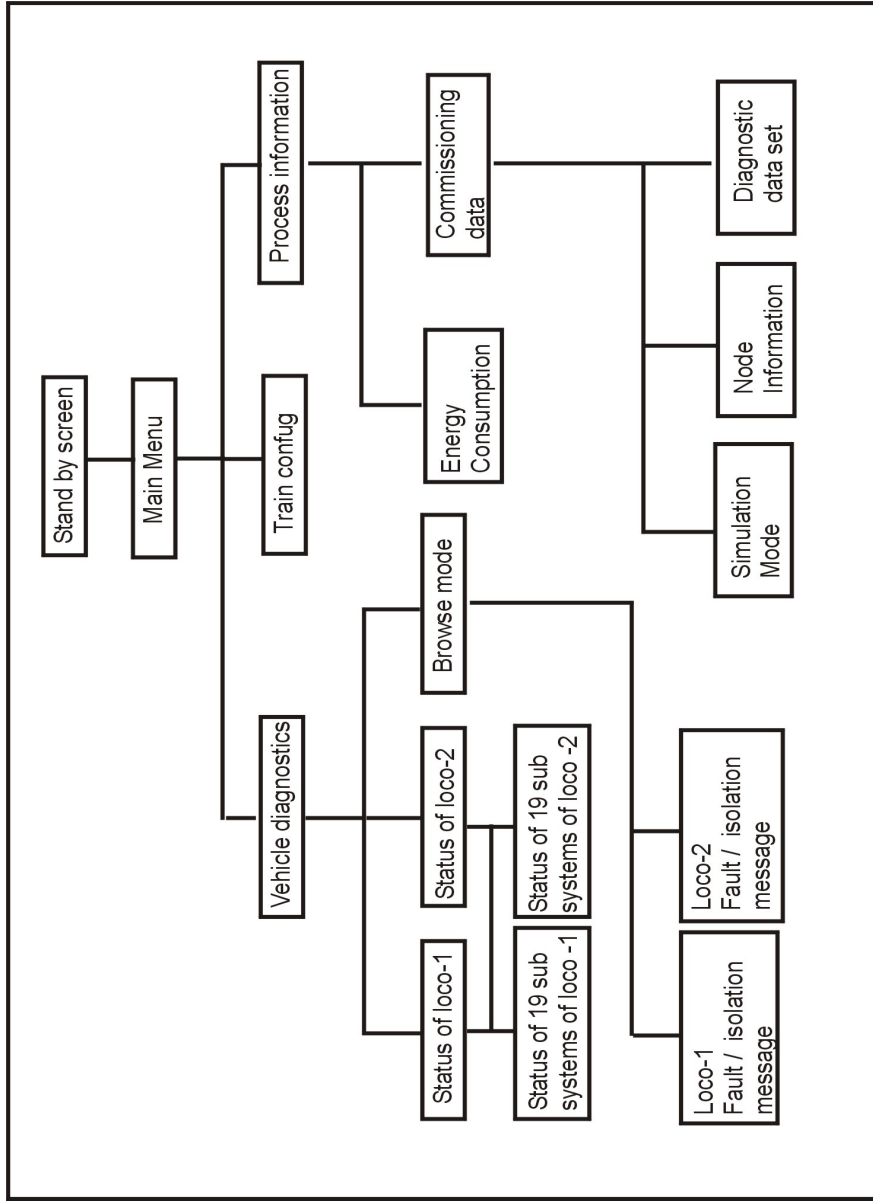

11.3 Faults With Priority-1:

- The action to be taken is entirely clear.
- The action to be taken must be initiated immediately.
- A protective action is initiated (VCB OFF)
- BPFA will glow.
- LSF1 will flicker.
- Priority-1 message will display.

11.4 Faults With Priority-2:

- The action to be taken is not entirely clear.
- The action to be taken does not have to be initiated immediately.
- The faults can be remedied manually by driver.
- BPFA will glow.
- Priority-2 message will appear on screen.

Note:

- If a fault message appear on the screen, the yellow illuminated push button "BPFA" lights up. If this is fault of priority-1, the red indication lamp "LSFI" starts flashing at the same time.
- If a fault message with priority-1 is displayed, a fault message with priority-2 is suppressed on the screen.
- A fault message with priority-2 remains on the screen until it is overwritten by a fault message with priority-1 or by subsequent fault with priority-2.

11.5 Isolation Of Sub System:

A constant priority-1 fault or priority-2 fault which occurs twice within one 30 minutes period causes the appropriate subsystem to be isolated.

If sub-system has been isolated it does not issue any more fault message and signals. Only LSF1 remains glowing.

11.6 Acknowledgement Of Fault Message:

Priority-1

If a priority-1 fault occurs the fault message must be acknowledged before the loco can travel further, If the train driver fails to acknowledge, the protection measures introduced remain in force. The fault is not remedied.

- Fault message can be acknowledge by pressing BPFA, if after acknowledgement LSF1 extinguish then it indicates now loco is normal, but if LSF1 glow continuously it indicates isolation of concerned sub-system.

Priority-2

They are also acknowledged by pressing BPFA. Even if this acknowledgement is not forthcoming, the locomotive is still able to operate. The fault message still remains visible on the screen until it is over written by a fault message with priority-1 or by subsequent fault with priority-2.

11.7 Indication And Recognition Of Faults**Illuminated push button (BPFA):**

Fault indication/fault acknowledgement (Yellow) On occurrence of any fault, the illuminated push button for fault acknowledgement will light up and fault message will appear on the display. The driver is required to acknowledge the fault through the push button. On acknowledgement, the lamp of acknowledgement push button will go off and the display will be cleared.

Fault status lamp (Red) (LSF1) :

In case of priority 1 fault, the fault status lamp will start blinking additionally. On acknowledgement of fault, the lamp will be off but if there is an isolation of a subsystem persisting, then the lamp will continue to glow.

Automatic display of diagnosis messages

If a fault occurs that needs to be transmitted to the driver by means of a diagnosis message, such message will be displayed immediately. At the same time, the illuminated push-button for fault acknowledgement will light up.

All diagnostic messages shall be acknowledged by the driver through the fault acknowledgement push button(BPFA). On acknowledgement, the lamp of acknowledgement push button will go off and the display will be cleared.

In case of priority-1 fault, the fault status lamp (LSFI) will start blinking additionally. On acknowledgement of fault the lamp will be off but if there is an isolation of a subsystem persisting, the lamp will continue to glow.

If the driver fails to acknowledge priority 1 fault, then the loco is shut down.

If the driver fails to acknowledge faults of priority 2 then the fault message will remain on the display screen, unless it is overwritten by a fault message of priority 1.

The fault or isolation messages include following information:

- Locomotive number on which the fault or the subsystem isolation respectively occurred
- Name of subsystem being affected (SS01 to SS19)
- Type of fault /subsystem isolation and related consequences
- Instructions to the engine driver

11.8 Status Code

STATUS CODE

FIRST DIGIT

0- No sub system isolated
9- at least one sub system isolated

SECOND DIGIT

0- no fault WITH priority -1 OR 2
1- at least one Priority-2 fault
2- at least one Priority-2 fault

- 0 0 No fault and no sub system isolated
- 0 1 No sub system isolated, at least one Priority-1 fault
- 0 2 No sub system isolated , at least one Priority-2 fault
- 9 0 At least one sub system isolated , no fault
- 9 1 At least one sub system isolated , at least one Priority-1 fault
- 9 2 At least one sub system isolated , at least one Priority-2 fault
DTC/AQ

11.9 Fault Message Code

Under standing fault number

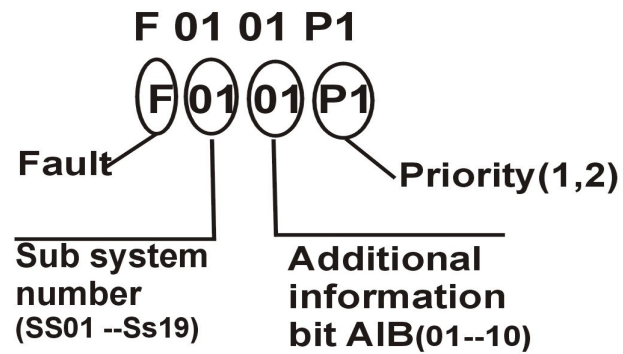

11.10 Display Of Subsystem Status

By means of keyboard entry, the driver can display the status of all subsystems of all locomotives within the train composition. Different display levels furnishing more or less detailed information are provided:

- Survey of all locomotives within the train composition: the status of each individual locomotive is indicated by a two-digit numerical code.
- Survey of all subsystems within one locomotive: the status of individual subsystem is indicated by a two-digit numerical code.

11.11 Browse Of Status Messages On Request

All diagnosis messages that appeared at the display since the last activation of the control system may be repeated on request. In this way, the relieving operating personnel is kept informed on the status of the vehicle. If the train composition consists of two locomotives, the driver can select the locomotive that he wants to process first.

11.12 Diagnosis Messages

There are three types of messages displayed to the driver on the display unit in the cab:

1. Information messages
2. Fault messages
3. Isolation messages

11.13 Fault & Isolation Message Structure

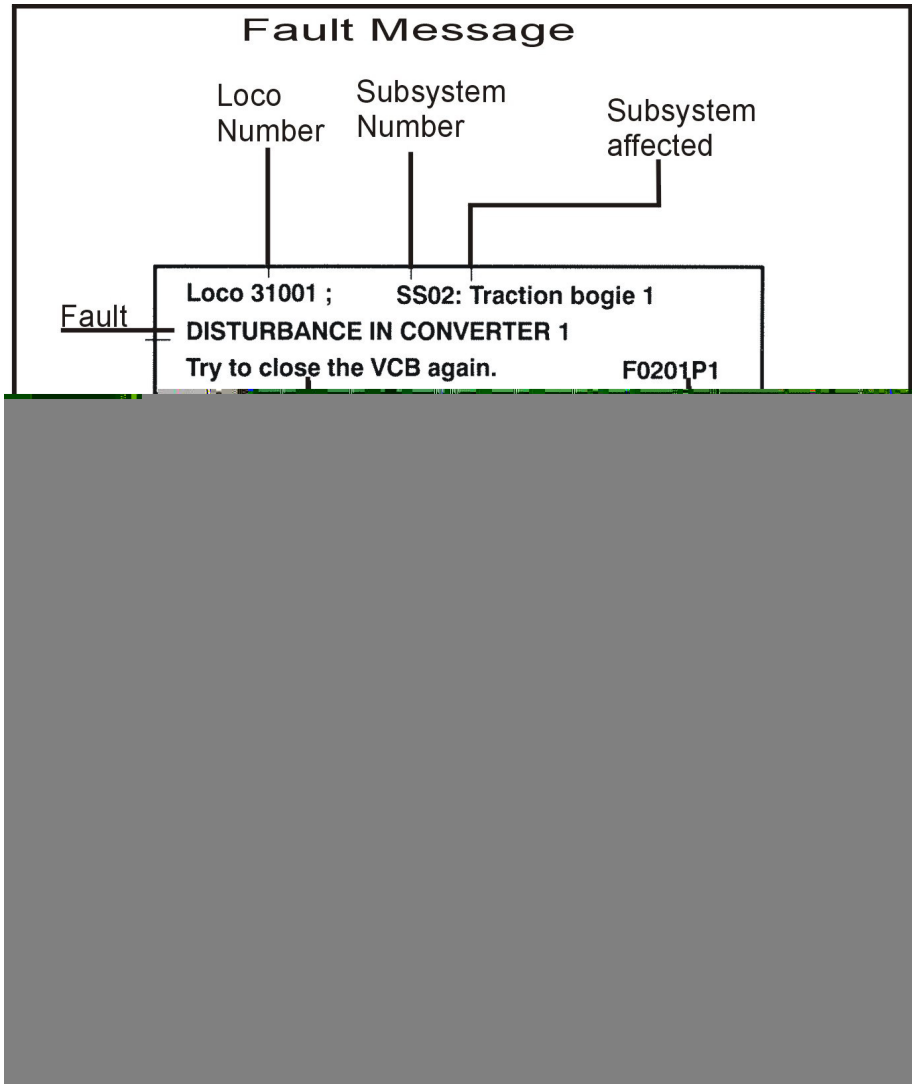

11.14 Subsystems

SS01	Main power
SS02	Traction Bogie 1
SS03	Traction Bogie 2
SS04	Harmonic filter
SS05	Hotel load
SS06	Aux Converter 1
SS07	Aux Converter 2
SS08	Aux Converter 3
SS09	Battery System
SS10	Brake System
SS11	Auxiliaries HB1
SS12	Auxiliaries HB2
SS13	Cab 1
SS14	Cab 2
SS15	Fire detection
SS16	Speedometer
SS17	Processor FLG1
SS18	Processor FLG2
SS19	Trainbus

11.15 List Of Isolation Messages

SSO1: Main power

MAIN POWER ISOLATED; VCB inhibited
Loco is dead Ask for relief loco

SSO2: traction bogie 1

BOGIE 1 ISOLATED; Only half traction and braking power available
Inform maintenance staff

SSO3: Traction bogie 2

BOGIE 2 ISOLATED; Only half traction and braking power available
Inform maintenance staff

SS04: Harmonic Filter

HARMONIC FILTER ISOLATED

Speak to TLC Reduce speed below 40 km/h

Inform maintenance staff speaks to TLC

SS06: Aux.converter 1

AUXILIARY CONVERTER 1 ISOLATED

Driving still possible Max. Ventilation level will be reduced

Inform maintenance staff

SS07: Aux.onverter

AUXILIARY CONVERTER 2 ISOLATED

Driving still possible Max. Ventilation level will be reduced

Inform maintenance staff

SS08: Aux.onverter

AUXILIARY CONVERTER 3 ISOLATED

Driving still possible Max. Ventilation level will be reduced

Inform maintenance staff

SS13: Cab 1

CAB 1 ISOLATED Drive from Cab 2 Change to Cab2

Inform maintenance staff

SS14: Cab 2

CAB 2 ISOLATED Drive from Cab 1 Change to cab-1

Inform maintenance staff

S517: FLG 1

FLG1 ISOLATED

No multiple operations possible, Inform maintenance staff

SS18: FLG 2

FLG2 ISOLATED

No electrical brake power available, Inform maintenance staff

SS19: Train bus

TRAINBUS ISOLATED

Multiple operations not possible ,Inform maintenance staff

11.16 List Of Information Messages

Information 001

SELF HOLD MODE ACTIVE for 10 mm. MCE will switch off
Change cab or repair train or multiple operations within 10 minutes

Information 002

MORE THAN ONE CAB ACTIVE
Deactivate non-driving cab otherwise after 10 mm. MCE switches off

Information 003

Traction MAY NOT BE AVAILABLE ON THIS LOCO OR ON THE SLAVE
LOCO
Bring throttle to 0 . then set again Bring TE/BE throttle to “0” and set it again

Information 004

TRAINBUS CONFIGURATION RUNNING Please wait

Information 005

FULL TE/BE RESTORED+

Information 006

PANTO RAISING Please wait

Chapter - 12

Multiple Unit Operation

Multiple operation with two locomotives

In multiple operations a maximum of two locomotives can be operated. Both must be directly coupled to one another. They must not be separated by a carriage.

While in motion, the front driver's cab is usually activated.

When linking up or in unusual situations, it is also possible to control the locomotives from another driver's cab.

The train bus configuration for multiple operation is only possible from the driver's cab at the uncoupled end. A configuration from a rear driver's cab is referred to as single-unit traction. The train bus automatically checks the configuration :

The leading manned locomotive is called the master locomotive and the other one is called the slave locomotive.

The two locomotives are correctly linked together once the mechanical and pneumatic systems and the UIC cable have been connected.

Commands are transmitted down the UIC cable.

Pantograph

In multiple operation, both the most distant pantographs are raised if "pantograph selection switches" in both the locomotives are in position "AUTO".

The train bus connections define the free end of each locomotive.

The command from the master locomotive to raise/lower the pantographs also controls the pantographs on the slave locomotive.

Note :

Whenever the pantograph key switches on the master and slave locomotives are not in the same position, the pantograph are not active (fault message).

Main circuit breaker

The command from the master locomotive to switch the main circuit breaker "ON/OFF" also control the main circuit breaker on the slave locomotive.

The VCB on the slave locomotives is switched on after a delay of 0.5 seconds following the switch on of the VCB on the master locomotive. When switching off, there is no delay.

Note :

If the VCB on the slave locomotive cannot be closed due to a fault, an appropriate fault message appears on the screen.

Regenerative brake

During multiple operation, there is a limitation on the regenerative brake on the slave locomotive. This limitation reduces forces on the loco buffers (prevention of derailling).

Constant Speed Control (CSC)

During multiple operation, the constant speed control of the slave locomotive is inactive. The train bus transmits the selected tractive/braking effort from the master locomotive to the slave locomotive. The master loco performs speed controlling function, demanding TE/BE on master and slave loco.

Anti-spin protection

The anti-spin protection of the slave locomotive is independent of the master locomotive.

Compressor control

The compressors are able to operate in three different operating modes.

These modes can be selected with the spring-loaded switch “BLCP”, (Panel A).

Pos. “Off” Compressor switched off.

Pos. “Auto” Automatic pressure monitoring.

Pos. “Man” Compressor switched on (manual monitoring).

The selected position of the compressor switch is transmitted to the slave locomotive.

In the “Main” and “Off” positions, all main compressors in both locomotives are controlled directly.

In the position “Auto”, there are the following options :

1. A main reservoir pressure below 8 kg/cm² on the master or slave locomotive activates a particular compressor on both locomotives. Each locomotive switches alternately and independently between its two compressors.
2. A main reservoir pressure below 8.5 kg/cm² on the master or slave locomotive activates all compressors on both locomotives at the same time.
3. At a main reservoir pressure below 6.4 kg/cm², each locomotive independently control its compressors.

Parking brake

The multiple unit cannot drive if one of the parking brakes is applied.

Note :

An activated parking brake on the master or slave locomotive is indicated in the activated driver's cab of the master locomotive by the red illuminated push button "BPPB".

Emergency Brake

An emergency brake on the slave locomotive can only be initiated in the following manner :

1. By actuating the brake handle of the automatic train brake to "Emergency" position.
2. By actuating the emergency brake cock on the assistant driver's side. If the pressure switch 269.1 on the master or slave locomotive registers actuation of the emergency brake, the ensuing command for emergency braking applies to both locomotives.

The master for all other emergency braking commands is the master for all other emergency braking commands is the master locomotive in the double (multiple) unit.

Other Brake functions

If the pressure switch (269.6) registers a pressure in the brake cylinder of any bogie, and if speed exceeds 10 km/h, tractive effort is set to 0.

Note :

If the electrical brake on one of two locomotives fails, the electrical brake on the other locomotive remains functional.

Coupling

1. Both locomotive must be deactivated.
The key switch must be in position "0"
2. Couple both locomotives mechanically, pneumatically and connect the UIC cable.
3. Close the isolating cock on the brake supply line of the slave locomotive.
4. Move the key switch on the slave locomotive into position "D" and, as soon as the light test starts, turn back to position "0". The MCE on the slave locomotive is now in self-hold mode.
5. During the self-hold mode of the slave locomotive, move key switch into Pos. "D" on the master locomotive. The control electronics starts to configure the train bus.
6. After the configuration procedure, screen on the display shows the serial numbers of the master and slave locomotives.

Example :

Train configuration	
Loco 31001	Loco 31002

Note :

If configuration proves impossible, (or if no locomotive is available) locomotive number 00000 appears.

If more than one driver's cab is activated in both locomotive, one is shutdown and a corresponding message appears on the displays in both locomotives.

Uncoupling

Starting position :

Master and slave locomotives are available and both are ready.

1. Shut down both locomotives in accordance with regulations (VCB switched off, pantograph lowered).
2. Remove the UIC cable and disconnect the locomotives pneumatically and mechanically.
3. Both the locomotives are now ready for setting up as a single locomotive.

Note :

If for any reason the train bus link is interrupted, or if both locomotives are set up or in motion, the system protection initiates a monitored shut down of the slave locomotive.

Reaction :

The pantograph of the slave locomotive is lowered and a corresponding fault message appears on the screen of the master locomotive.

Sanding

Sanding on both locos can be initiated by the driver by pressing the sanding foot switch on the master loco.

Fire alarm

A fire detection on the slave locomotive initiates an audio signal on the master locomotive.

In addition, the VCB on the slave locomotive is switched off and a priority 1 fault message appears on the displays of both locomotives.

Trailing mode

Trailing mode means that on the master locomotive in a multiple unit no tractive effort is available, if both bogies are electrically isolated. The driver's cab of the master locomotive still controls the slave locomotive.

The status of the master locomotive is as follows :

1. VCB switched off.
2. Pantograph is lowered.
3. Train bus is working correctly.
4. Pneumatic brake system is working correctly.
5. Brakes are controlled from the master locomotive.
6. The TE/BE meters show the values for the slave locomotive.

Note :

All equipments on the master locomotive are supplied by the battery and are functional for a maximum of 5 hours, if battery is fully charged.

Chapter – 13

Procedure of wheel lifting

The axle of locomotive get locked under the following circumstances:

- Traction Motor Bearing Seizure
- Traction motor suspension bearing seizure.
- Axle box roller bearing seizure.

While it may be possible to free three traction motor in case of traction motor bearing seizure, the other cases require floating / lifting of the affected wheel for movement of the locomotive. Floating / lifting of the affected wheel may become necessary in case of wheel flats & heavy skidding of wheels also.

Procedure when Traction Motor Roller Bearing gets seized:

In case of traction motor roller bearing seizure, the pinion of the affected motor should be removed and all the traction motors of the affected bogie should be electrically isolated. The locomotive should be worked as light engine on its power to the nearest Electric Locomotive Shed for attention.

However, where removal of the pinion is not possible due to any reason, the locked axle should be floated following the procedure below for clearing the section.

Procedure for Floating / Lifting the Locked Axle:

In case when axle gets locked due to Axle Roller Bearing Seizure, Traction Motor Suspension Bearing Seizure, Wheel Flat or Heavy skidding of Wheels, the affected axle should be floated / lifted (depending on the axle number) after electrically isolating all the motors of affected bogie. The locomotive should be worked as a light engine on its own power with a maximum restricted speed of 25 km/h under escort by maintenance staff. In such case, a close watch is necessary while passing over curves and turnouts.

Precautions to be taken

Before attempting the lifting of locked axle of the locomotive, the steps given below should strictly be followed to avoid damage to equipment or any mishap.

- i. Apply wooden wedges at wheels to prevent rolling of locomotive.
- ii. Release all TBUs (brakes) of the affected bogie, which requires lifting.
- iii. Before application of jacks for lifting, ensure that the ground below the lifting jacks is firm and leveled. Due care must be taken to avoid slipping of the jacks.
- iv. Isolate all the traction motors of the affected bogie.

- v. Remove all primary vertical dampers of the affected bogie to avoid their damage.
- vi. Remove links between axle box and bogie frame from middle axle of the affected bogie.

When One of the End Axles (i.e Axle Nos. 1, 3, 4 or 6) gets Locked

- i. Dismantle the slack adjuster of the locked end axle wheels.
- ii. Clamp the vertical brake hanger levers of locked axle at appropriate place with the bogie frame to prevent fouling of these levers with the wheel set trolley during movement.
- iii. Dismantle the sand box pipes. Remove footsteps, if required.
- iv. Remove the vertical dampers between the bogie frame and axle boxes of locked end axle of the affected bogie.
- v. Lift frame of the affected bogie from the end at the other side of the locked axle (e.g. from the end near axle No. 3 if axle No. 1 is locked) to obtain a clearance of 75 to 80 mm between axle box top and bottom of the bogie frame at both sides by simultaneously applying two jacks of minimum 15t capacity each below the axle guide bracket / bogie end beam.
- vi. Place the Resilient Block Between axle box top and bottom of the bogie frame at both the sides and release the jacks.
- vii. Now lift the locked end axle of the affected bogie simultaneously from both sides by applying two jacks of minimum 15t capacity each under the bogie end beam / axle guide bracket. The bogie frame should be lifted to obtain sufficient clearance between axle box top and bottom of the bogie frame at middle axle.
- viii. Place the resilient block between axle box top and bottom of the bogie frame at both the sides at middle axle location and release the jacks.
- ix. While releasing the jacks, it must be ensured that the springs are properly seated.
- x. Now, lift the locked end axle by 55 to 60 mm by simultaneously applying two jacks of minimum 15t capacity each below the axle housings at both sides.
- xi. Assemble the wheel set trolley below the locked end axle over the track in such a way that the wheels of locked axle rest over the supporting rollers. Refer procedure given below for Assembly of Wheel Set Trolley.

- xii. Sketch 4 shows the locations of the application of jacks for lifting and arrangement of wheel set trolley under the affected end axle.
- xiii. Release the jacks from both sides of the locked end axle ensuring that the defective wheels of the locked axle rest properly on the rollers of the wheels set trolley.
- xiv. Remove the wooden wedges placed at wheels of the locomotive.
- xv. Locomotive with affected wheel set placed on the wheel set trolley cleared dead at a restricted speed not exceeding 25 km/h to clear the block section.

Trolley (towing equipment)

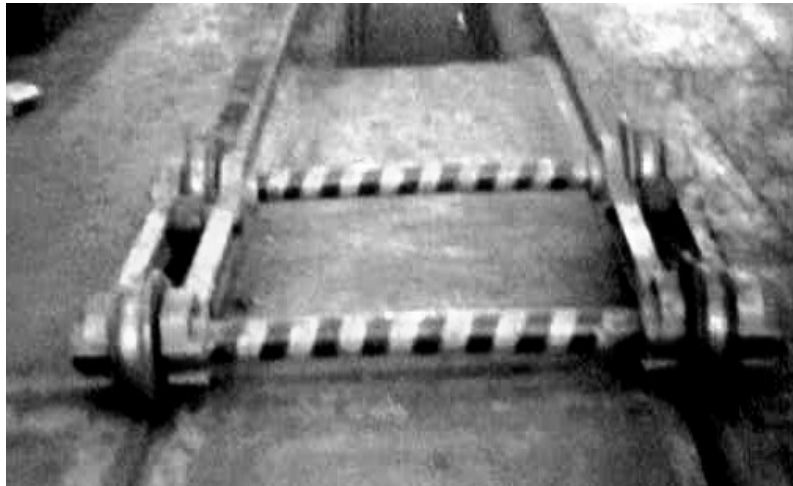

Procedure For Assembly of Wheels Set Trolley:

- i. The locked wheel set has to be lifted up approximately by 55 mm to 60 mm.
- ii. Push both the inner Longitudinal Frames of trolley under the locomotive.
- iii. Place both the steel Tubes in position.
- iv. Lift up the frame along with the steel tubes, push in and fasten the running Wheel Arrangements, Supporting Roller Arrangements .
- v. Push the outer Longitudinal Frames of the trolley under the locomotive; lift the frame, push in Outer Steel Tubes / Sleeves and fasten the frames with keys and nuts.
- vi. To facilitate easy assembly of wheel set trolley, suitable markings must be provided to identify the matching parts.
- vii. Lower the locked wheel set of the locomotive gradually on the supporting rollers.
- viii. After lowering the wheels on trolley, it is essential to ensure that the wheel flanges of the lifted wheel set are sufficiently clear from the rails, to avoid hitting / infringement during movement of the locomotive.

When Middle Axle (i.e. Axle No. 2 or 5) gets Locked:

- i. Lift the bogie frame of the affected bogie from one end by applying two jacks of minimum 15t capacity each simultaneously at both sides (RHS & LHS) below the axle guide bracket / bogie end beam to obtain a clearance of 105 to 110 mm between axle box top and bottom of the bogie frame.

Short links between axle box cover and bogie frame

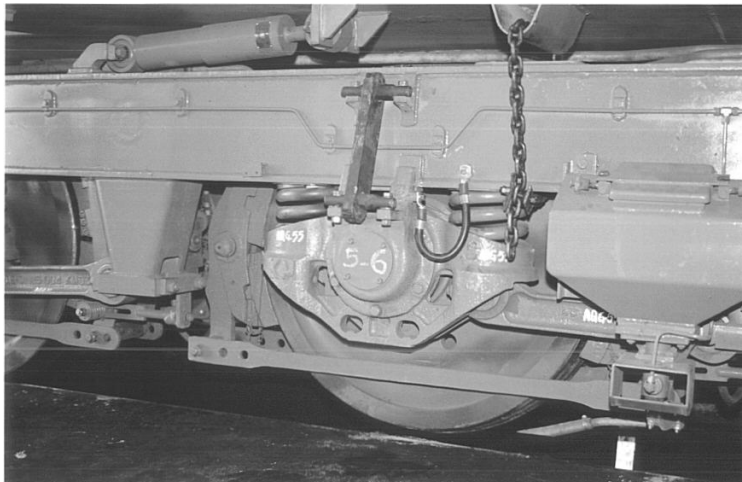

- ii. Place the resilient Block at the top of the axle box in center position at both the sides (RHS & LHS) of this end axle and release the jacks gradually till the bogie frame rests on the resilient blocks. While releasing the jacks it must be ensured that the springs are properly seated.
- iii. Now lift the bogie frame of the affected bogie from the other end axle from both the sides (RHS & LHS) simultaneously by applying two jacks of minimum 15 t capacity each under the bogie end beam / axle guide bracket to obtain clearance of 105 to 110 mm between axle box top and bottom of the bogie frame at this end.
- iv. Place the Resilient Block at the top of axle box in center position at both the sides (RHS & LHS) of this end axle and release the jacks gradually till the bogie frame rests on the resilient blocks. While releasing the jacks it must be ensured that the springs are properly seated.
- v. Now, lift the locked middle axle simultaneously by applying two jacks of minimum 15t capacity each below the axle box housings at both sides (RHS &LHS).
- vi. Mount short links between axle box cover and bogie frame at both sides (RHS & LHS) using existing pins of middle axle links.
- vii. It can be seen that the wheel flanges of the affected axle are lifted approximately by 40 to 45 mm from rail level.
- viii. Remove wooden wedges placed at wheels of the locomotive.
- ix. The locomotive with effected wheel set lifted can now be moved on its own power at a restricted speed not exceeding 25 km/h to clear blocked section after isolating all the motors of the affected bogie.

Chapter - 14**DEAD LOCO MOVEMENT**

(FOR DETAILS, REFER RAILWAY BOARD LETTER No. **2000 /M (L) /466/803/Pt. dated 28.06.2006**)

Hauling 3-Phase loco fitted with E-70 brake system as a dead loco.

These locomotives are fitted with electro pneumatic E-70 brake system. These locomotives in dead condition can be hauled both by locomotive fitted with IRAB-1/28LAV-1 brake system and locomotive fitted with E-70 brake system.

If these locos are coupled with conventional A.C. locos as a dead, then direct loco brake application is not possible by SA-9 since MRE & BCE can not be coupled but if BP is dropped from live loco, conjunction loco brakes application will take place in dead loco.

A) Hauling dead WAP-5/WAG-9 electric locomotive fitted with E-70 brake pipe control system in a train.

1. Switch off BLDJ and lower the pantograph of the loco to be sent as dead. Isolate the pantograph through panel isolating cock on pneumatic panel.
2. Switch off CEL as follows:
 - a) Operate BL-key from 'D' to 'Off' (wait for 2 sec.)
 - b) Operate BL-key from 'Off' to 'C' and wait until display screen, LSDJ, and UBA goes off.
 - c) It indicates that CE is get 'OFF' and now rotate BL from 'C' to 'OFF'. Switch off the 'circuit breaker control circuit locomotive' (112.1) in SB2 panel.
3. Couple the dead loco in the train.
4. Put auto brake controller (A9) in "Neutral" position in both cabs of dead loco.
5. Put the direct brake controller (SA9) in "Release" position in both cabs of dead locomotive.
6. Drain the Main and Aux. reservoirs of dead locomotive completely. After draining out, close the drain cock of main reservoir and aux. reservoir.
7. If loco brake in the dead locomotive have not got released, which can be verified by observing the BC pressure gauge, then release the same in the following steps.

- ii) Manual handle of distributor valve at pneumatic panel should be operated manually to release control pressure. BC pressure shall automatically vent through D2 relay valve to release loco brakes.
- iii) In case residual BC pressure remains in brake cylinder line, the BC pressure should be released through bogie isolating cock of both bogies. Make bogie-isolating cocks in 'Normal' position after releasing the BC pressure

8. In the dead locomotive, ensure isolating cock position in the pneumatic panel as follows. (Towed dead):

Cock	47 (Dead Engine)	74 (Emergency/ Vigilance)	136 (Brake Feed Pipe)	70 (E-70 brake pipe)
Position	Open	Closed	Closed	Closed

9. Connect BP pipe of the dead loco to the BP pipes of load and open BP angle cock of both of loco and load side. The aux. reservoir on dead locomotive will get charged from BP supply. Check the BP pressure gauge in the cab of dead loco. It should show the same pressure as that of the load in case of load (In case of locos are to be attached on a train having twin pipe i.e. both BP and FP then FP of dead locos should also connected and its angle cock should be opened.)

10. Lock the parking brakes in applied condition. This procedure is safe to avoid brake binding and condensation of moisture in the parking brake cylinder. It is as under

- a) Apply the parking brakes of dead loco by apply push button.
- b) Lock the parking brakes in applied condition.
- c) Release the parking brake of the dead loco by manual operation of parking brake release handle on each of the four parking brake units. For manual brake release, first turn the release handle slightly clockwise and then pull till a sound of locking mechanism is heard. The parking brake units are fitted on the following wheels:

LOCO TYPE	WHEEL POSITION OF PARKING BRAKE UNITS			
WAP5	1	4	5	8
WAG9	2	6	7	11

- d) If some of the parking brake handles are defective and due to this if not possible to release manually, then release the same by manually pressing the "Release" Push Button of the latched

solenoid valve no.30 on the pneumatic panel of the dead locomotive.

11. As parking brakes are locked in applied condition PB gauge will show 0 Kg/Cm².
12. Double check the release of parking brakes of dead loco by moving the parking brake unit by hand.
13. Apply auto brakes (A9) in the working locomotive and check that loco brakes on both the locomotives are getting applied. Then release the auto brake in the working loco and check that loco brakes are getting released on both the locomotives. Rear locomotive (WAG-9 / WAP-5 dead) takes about 1 minute to release.
14. As a final check, run the coupled loco for about 500 metres and feel for any abnormal rise in temperature of wheels of dead loco and also check if at subsequent stop during journey.
15. Remember that in the dead locomotive, the loco brakes takes about 1 minute to release after auto brake application from the live loco. Hence after every auto brake application and release wait for adequate time (minimum 1 minute) for release of loco brakes in dead locomotive before resuming traction
16. Escorts accompanied dead locomotive should never put BL key in position 'D' and also strictly avoid energising the dead locomotive.
17. After reaching the destination, before detaching the working loco,
 - a) Unlock the application plunger of parking brake solenoid valve no. 30.
 - b) Press the release button of parking brake solenoid valve no. 30. This will charge parking brake line by 5 kg/cm².
 - c) Apply parking brakes on dead locomotive by application plunger of parking brake solenoid valve no. 30.

B) Hauling dead WAP5/WAG-9 locomotive fitted with E-70 brake pipe control system when attached next to leading working locomotive:

1. Switch off BLDJ and lower the pantograph of the loco to be sent as dead. Isolate the pantograph through panel isolating cock on pneumatic panel.
2. Switch off CEL as follows:
 - a) Operate BL-key from 'D' to 'Off' (wait for 2 sec.)
 - b) Operate BL-key from 'Off' to 'C' and wait until display screen, LSDJ, and UBA goes off.
 - c) It indicates that CE is get 'OFF' and now rotate BL from 'C' to 'OFF'. Switch off the 'circuit breaker control circuit locomotive' (112.1) in SB2 panel.
3. Couple the dead loco in rear of the working loco.
4. Put auto brake controller (A9) in "Neutral" position in both cabs of dead loco.

5. Put the direct brake controller (SA9) in "Release" position in both cabs of dead locomotive
6. Drain the Main and Aux. reservoirs of dead locomotive completely. After draining out, close the drain cock of main reservoir and aux. reservoir
7. If loco brake in the dead locomotive have not got released, which can be verified by observing the BC pressure gauge, then release the same in the following steps.
 - i) Manual handle of distributor valve at pneumatic panel should be operated manually to release control pressure. BC pressure shall automatically vent through D2 relay valve to release loco brakes.
 - ii) In case residual BC pressure remains in brake cylinder line, the BC pressure should be released through bogie isolating cock of both bogies. Make bogie-isolating cocks in 'Normal' position after releasing the BC pressure
8. In the dead locomotive, ensure isolating cock position in the pneumatic panel as follows. (Towed dead):

Cock	47 (Dead Engine)	74 (Emergency/ Vigilance)	136 (Brake Feed Pipe)	70 (E-70 brake pipe)
Position	Open	Closed	Closed	Closed

9. Connect BP pipe of the dead loco to the BP pipe of working loco and open BP angle cock of both the locos. The aux. reservoir on dead locomotive will get charged from BP supply of the working locomotive. Check the BP pressure gauge in the cab of dead loco. It should show the same pressure as that of the live locomotive (In case of locos are to be attached on a train having twin pipe i.e. both BP and FP then FP of both the locos should also connected and its angle cock should be opened.)
10. Lock the parking brakes in applied condition. This procedure is safe to avoid brake binding and condensation of moisture in the parking brake cylinder. It is as under
 - a. Apply the parking brakes of dead loco by apply push button.
 - b. Lock the parking brakes in applied condition.
 - c. Release the parking brake of the dead loco by manual operation of parking brake release handle on each of the four parking brake units. For manual brake release, first turn the release handle slightly clockwise and then pull till a sound of locking mechanism is heard.

The parking brake units are fitted on the following wheels:

LOCO TYPE	WHEEL POSITION OF PARKING BRAKE UNITS			
WAP5	1	4	5	8
WAG9	2	6	7	11

d. If some of the parking brake handles are defective and due to this if not possible to release manually, then release the same by manually pressing the "Release" Push Button of the latched solenoid valve no.30 on the pneumatic panel of the dead locomotive.

11. As parking brakes are locked in applied condition PB gauge will show 0 Kg/Cm².
12. Double check the release of parking brakes of dead loco by moving the parking brake unit by hand.
13. Apply auto brakes (A9) in the working locomotive and check that loco brakes on both the locomotives are getting applied. Then release the auto brake in the working loco and check that loco brakes are getting released on both the locomotives. Rear locomotive (WAG-9 / WAP-5 dead) takes about 60 seconds to release.
14. As a final check, run the coupled loco for about 500 metres and feel for any abnormal rise in temperature of wheels of dead loco and also check if at subsequent stop during journey.
15. Remember that in the deal locomotive, the loco brakes takes about 60 seconds to release after auto brake application from the live loco. Hence after every auto brake application and release wait for adequate time (minimum 1 minute) for release of loco brakes in dead locomotive before resuming traction
16. Escorts accompanied dead locomotive should never put BL key in position 'D' and also strictly avoid to energise the dead locomotive.
17. After reaching the destination, before detaching the working loco,
 - a) Unlock the application plunger of parking brake solenoid valve no. 30.
 - b) Press the release button of parking brake solenoid valve no. 30. This will charge parking brake line by 5 kg/cm².
Apply parking brakes on dead locomotive by application plunger of parking brake solenoid valve no. 30.

C) Hauling dead locomotive fitted with IRAB-1/28LAV-1 brake system by WAP-5/WAG-9 locomotive

1. Set up the IRAB-1/28LAV-1 locomotives for hauling dead in normal condition.
2. Connect BP pipe of the dead loco to the BP pipes of working loco and open BP angle cock of both of loco and load side. The aux. reservoir on

dead locomotive will get charged from BP supply. Check the BP pressure gauge in the cab of dead loco. It should show the same pressure as that of the live locomotive (In case of locos are to be attached on a train having twin pipe i.e. both BP and FP then FP of both the locos should also be connected and its angle cock should be opened.)

3. Check the release of parking brakes/hand brakes of dead loco by moving the parking brake/hand brakes unit by hand and observing the clearance between the brake blocks/pads and the wheels wheel disc.
4. Apply auto brake (A9) in the working locomotive and check that loco brakes on both the locomotives are getting applied. Then release the auto brake in the working loco and check that loco brakes are getting released on both the locomotives.
5. As a final check, run the coupled loco for about 500 metres and feel for any abnormal rise in temperature of wheels of dead loco and also check if at subsequent stop during journey.
6. After reaching destination, before detaching the working loco, apply parking brake/hand brake on dead locomotive.

PART- B
TROUBLE SHOOTING
DIRECTORY

PART – C
DIFFERENT PHOTOGRAPHS
OF LOCO PARTS